

June 14, 1960

G. W. OWEN  
PYROPHORIC LIGHTER

2,940,286

Filed Dec. 2, 1958

2 Sheets-Sheet 1

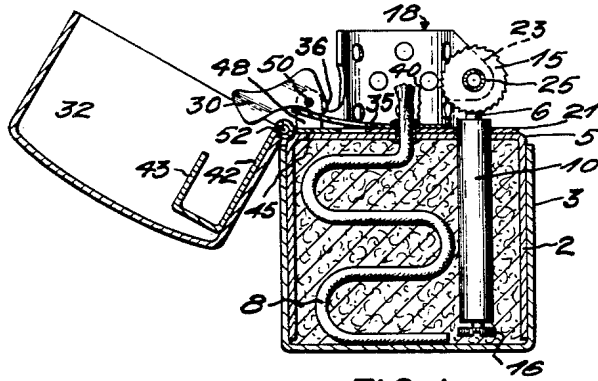

FIG. 1.

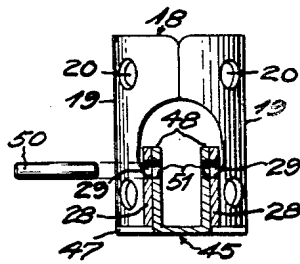

FIG. 3.

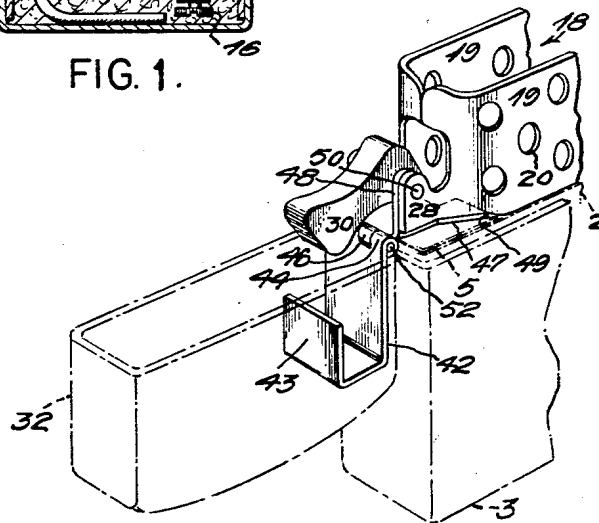

FIG. 2.

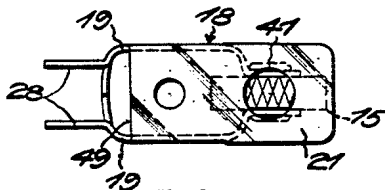

FIG. 4.

INVENTOR:

BY *George W. Owen*  
*Frederick W. White*

ATTORNEYS.

June 14, 1960

G. W. OWEN  
PYROPHORIC LIGHTER

2,940,286

Filed Dec. 2, 1958

2 Sheets-Sheet 2

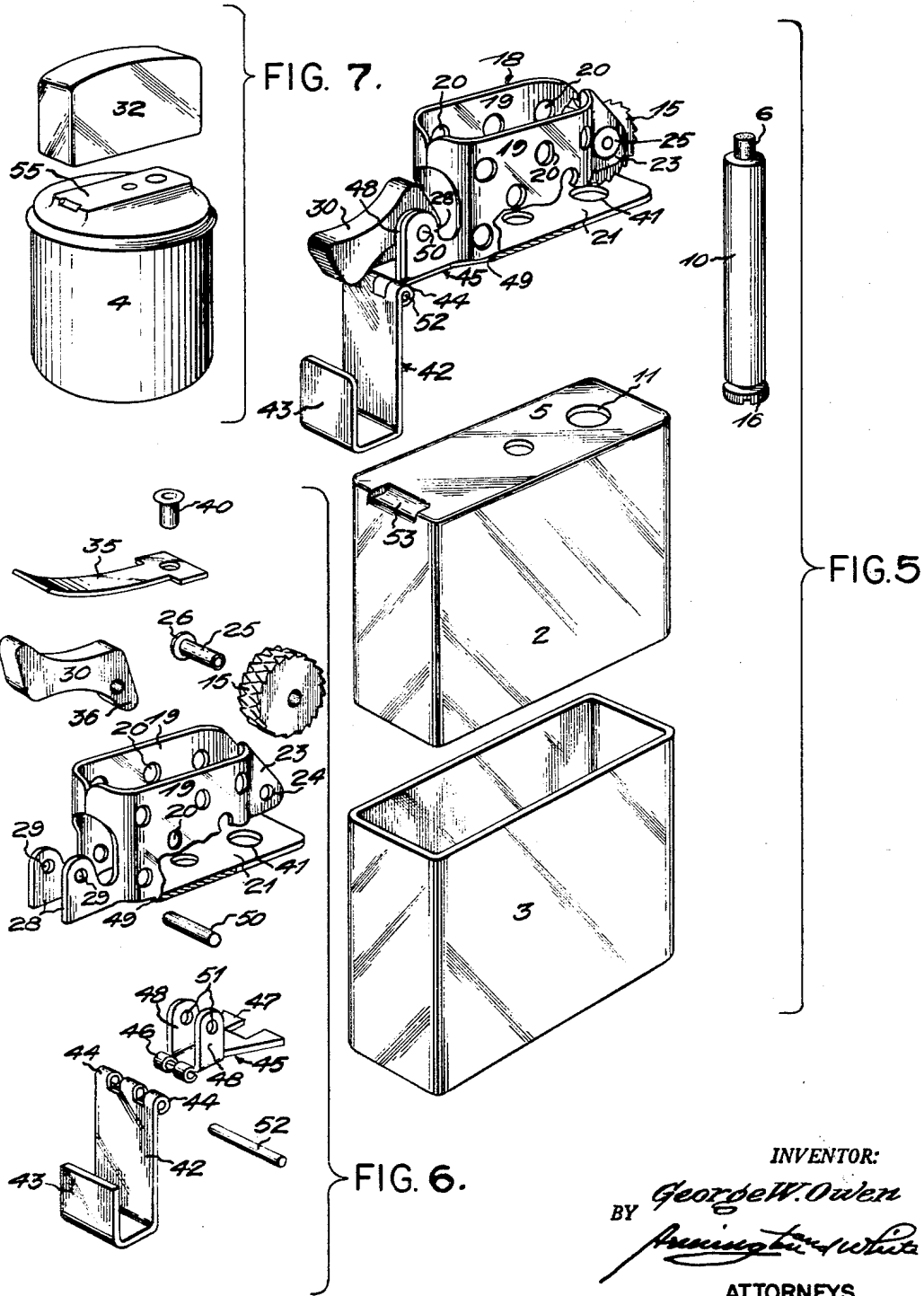

INVENTOR:

BY *George W. Owen*  
*Amington & White*

ATTORNEYS.

1

2,940,286

**PYROPHORIC LIGHTER**

George W. Owen, P.O. Box 654, North Attleboro, Mass.

Filed Dec. 2, 1958, Ser. No. 777,717

6 Claims. (Cl. 67-7.1)

This invention relates to cigar or cigarette lighters and consists of improvements in the construction thereof.

One object of the improvement is to provide a construction in which the parts subject to wear or damage in use may be readily removed from the lighter for repair or replacement.

Another object of the invention is to provide readily releasable means for attaching the hinge-elements of the cover to the main casing of the lighter to provide for their removal for repair or replacement.

Another object is to provide a hinge-element for the cover of the lighter that may be rigidly mounted on its casing without attaching it thereto by riveting, soldering, brazing or other permanent fastening means.

Another object is to provide a hinge-element on the lighter in which the means for detachably fastening it thereto may comprise standard parts of the original construction thereof.

Another object is to provide a hinge-element supported on the main part of the lighter by engaging under the base of the windscreen and secured in place by the pin used for pivoting the spring-actuated latch-lever that releasably holds the cover in closed relationship on the lighter.

Further objects of the invention are disclosed in the following specification and illustrated by the accompanying drawings, in which:

Fig. 1 is a vertical, sectional view taken through the center of the lighter and showing the operating parts thereof;

Fig. 2 is an enlarged fragmentary perspective view showing the hinged mounting of the cover for the lighter with the main portions thereof illustrated by dot-and-dash lines;

Fig. 3 is an enlarged elevational view showing the end of the windscreen with the hinge-element and the parts for attaching it thereto illustrated in transverse section to indicate the manner in which they are connected together by a cross-pin;

Fig. 4 is a similarly enlarged bottom plan view of the base-plate of the windscreen by which it is mounted on the top of the fuel-chamber;

Fig. 5 is a perspective view of the main parts of the lighter shown as disassembled;

Fig. 6 is a perspective view of the operating parts of the lighter shown as disassembled and illustrating the wall of the windscreen as partly broken away to reveal its base; and

Fig. 7 is a composite perspective view showing a different construction of the fuel-chamber of the device adapted for use in the construction of table lighters.

The present improved cigar or cigarette lighter may be of conventional form comprising an inner reservoir or fuel-chamber with means mounted thereon for igniting the end of a wick protruding from the top by striking sparks from a pyrophoric element or flint.

The fuel-reservoir or chamber may be embodied in a hollow rectangular casing 2 as shown most clearly in

2

Fig. 5, and in accordance with a preferred form of construction it may be fitted to telescope within an outer housing or casing 3, sometimes constructed of precious metal such as gold or silver for ornamentation by engraving or the like. In other instances, however, the fuel-chamber may take different shapes such as the cylindrical container 4 illustrated in Fig. 7 to adapt it to fit within an ornamental enclosure having a base or supported from a standard or pedestal.

As is usual in pocket lighters of the type shown herein, the fuel-chamber or reservoir 2 may have flat sides and ends closed at the top by a plate 5. The bottom of the chamber 2 may be open thereacross for receiving the fuel which is usually held in suspension by a packing of cotton or other suitable absorbent material (Fig. 1). When assembled with the outer casing 3 the bottom of the latter closes the open bottom of the chamber 2, or in other instances a separate closure may be provided with means for opening it for filling the chamber with liquid fuel. A wick 8 is housed within the fuel-chamber 2 with one end protruding through an opening in its top wall 5. The pyrophoric element or flint 6 which is of cylindrical form is slidably mounted in a vertical tube 10 having its upper end projecting through an aperture 11 in the top of the chamber 2. A helical spring (not herein shown) held in the tube 10 acts to maintain the end of the flint 6 engaging against the serrated periphery of a disk or wheel 15 which is rotatably mounted above the chamber 2, with a screw 16 in the bottom of the tube 10 holding said spring under compression.

For protecting or shielding the flame from drafts a windscreen 18 is usually provided on top of the fuel-chamber 2 (Figs. 1-5). The windscreen 18 may be constructed with vertical side walls 19 turned inwardly at the ends and perforated with a plurality of apertures 20 for the air to circulate therethrough. The windscreen 18 may be generally of oblong shape in plan view and constructed integral with a base-plate or bottom wall 21 by a forming operation in dies, or in other instances it could be made separate therefrom and attached to said base-plate by soldering or otherwise. As shown more particularly in Figs. 3, 4 and 5, the side walls of the windscreen 18 are curved inwardly at its right-hand end and then bent outwardly in a pair of triangular-shaped ears 23. The ears 23 are pierced with holes 24 (Fig. 6) to receive a tubular pivot-pin 25 for rotatably mounting the striking wheel 15 with its serrated periphery projecting through an opening at the end of the windscreen 18 for engaging the end of the flint 6. The pin 25 has a head 26 at one end and its opposite end may be flanged or headed over to fasten it in the holes 24 in the ears 23.

At the opposite end of the windscreen 18 the side walls 19 are curved inwardly at the top and cut away toward the bottom to form a pair of ears 28 for rockably mounting a latch-lever 30 which is of usual construction for cooperation with a hollow cap or cover 32. A pin 50 held in holes 29 in the ears 28 serves as the pivot for the latch-lever 30. As is a conventional construction for lighters of the present type, the cover 32 is hinged at one end of the casing 2 to adapt it to be pivoted into open position as shown in Fig. 1, or swung down against the top of the casing to enclose and protect the operating parts mounted thereon. Referring particularly to this latter view, a leaf-spring 35 is secured at one end flat against the top of the base 21 of the windscreen 18 with its forward end curved upwardly for engagement with the rounded toe portion 36 at the pivoted end of the latch-lever 30.

The spring 35 is fastened against the top of the base-plate 21 of the windscreen 18 and the base-plate itself held down against the flat top of the fuel-chamber 2 by means of an eyelet 40 headed over at its ends to form

a hollow rivet. The eyelet or hollow rivet 40 thus provides means for holding the wick 8 which has its end inserted therethrough to project upwardly within the confines of the windscreen 18. It will also be observed by reference to Fig. 1 that the upper end of the flint tube 10 projects through a hole 11 in the top of the chamber or casing 2 and a hole 41 in the base of the windscreen 18, either having a drive fit therein or being soldered in the hole in the top of the chamber. Through this form of construction economy in the cost of manufacture is secured by the elimination of rivets, screws or other fastening means. However, if desired the base-plate 21 of the windscreen 18 may be soldered or brazed to the top wall of the chamber or reservoir 2.

In accordance with a usual form of construction the cap or cover 32 is provided with a hinge-member 42 in the form of a flat metal strip fastened to the inside of its end wall and formed at one end with hinge-ears 44 (Figs. 2 and 6). The hinge-member 42 may be soldered to the end wall of the cover 32 or in other instances gripped frictionally therein as described in United States Letters Patent No. 2,774,234 of December 18, 1956. The member 42 has its opposite end bent at right-angles and then inwardly in parallel relation to its main length to form a square hook 43 for cooperation with the latch-lever 30. When the cover 32 is closed the member 42 will engage the free end of the latch-lever 30 to pivot it clockwise and compress the spring 35 for causing it to snap the cover down against the top of the casing. In this way the latch-lever 30 engages its flat end with the top of the spring 35 and is held resiliently for releasably latching the cover in closed relationship. As the cover 32 is swung into open relationship the opposite intumed hooked end 43 of the member 42 engages under the latch-lever 30 to rock it counterclockwise and cause the spring 35 to swing the cover open with a snap action in the manner well known to those versed in the art.

Referring to the detailed view of the two hinge-elements at the bottom of Fig. 6, the member 42 is usually constructed with three hinge-ears 44 curled over at its end; whereas, the fixed hinge-element 45 may have only two hinge-ears 46. A pin 52 is inserted through the ears 44 and 46 to connect the cover 32 to the casing 2 with a piano-type hinge. In lighters of the present type, the fixed hinge-element 45 is usually constructed integral with the inner casing of the lighter or it may be permanently fastened thereto by soldering, brazing or the like.

It has been a common experience with lighters of the present type that repeated opening of the cover causes wear and strain on the hinges, particularly the fixed hinge-element and this part of the hinge is frequently fractured or broken away from its mounting. In such case the whole of the element to which the hinge is attached must be discarded or a new hinge part applied to the lighter. Such repair or replacement of the parts generally requires return of the lighter to the manufacturer with loss of its use and considerable expense for shipping and making the repair. Therefore, as an important improvement in the art, the present invention provides a detachable hinge-element on the lighter itself which when damaged can be easily removed and replaced by a new element by the user himself without return of the lighter to the factory.

Referring to Figs. 2, 3 and 6, the hinge-element 45 may be constructed of sheet-metal and formed with a flat base-portion 47 having a pair of lugs or ears 48 bent upwardly from the sides of its narrower forward end. Portions of the metal at the front of the lugs 48 are curled around in the hinge-ears 46, previously mentioned, while the rearward length of its base-portion 47 is widened in wedge-shaped contour with its edges conforming to the sides of the ears 28 at the forward end of the windscreen 18 where they merge into the side walls 19 of the screen. The base-portion 47 of the element 45 is of a thickness to adapt it to slide rearwardly in a slot or opening be-

tween the bottom edges of the ears 28 on the windscreen 18 and the flat top of the casing 2 to cause its rearward edge to abut the forward edge 49 of the base-plate 21 (Figs. 2, 4 and 6). As will be observed by reference to the bottom plan view of the windscreen 18 (Fig. 4) the base 21 is recessed rearwardly to provide the relatively narrow slot or reentrant opening beneath the ears 28.

The vertical lugs 48 on the element 45 are of the same shape and dimensions as the ears 28 at the forward end of the windscreen 18, being perforated with holes 51 adapted to register with the holes 29 in the ears 28 (Fig. 3) to receive a pin 50 inserted therethrough for pivotally mounting the latch-lever 30. The pin 50 thus has another purpose, namely to secure the element 45 fixedly in place at the top of the casing 2 with its hinge-ears 46 registering with the ears 44 on the hinge-member 42 of the cover 32. The smaller pin 52, previously referred to, is inserted through the ears 44 on the member 42 and the ears 46 on the element 45 to hinge the cover to the casing 2 of the lighter. By this novel and ingenious form of construction the hinge-element 45 is securely fastened in place in the slot beneath the ears 28 on the windscreen 18 with its base portion 47 seated flat against the top of the casing and prevented from play or rocking motion thereon. Preferably, the top of the casing 2 is indented at its forward end to form a depression 53 (Fig. 6) providing clearance for the several hinge-ears 44 and 46. In this way the cover is hinged closely to the side of the casing 2 with the axis of its hinge in line with the end wall of the outer casing 3 to effect a smooth neat joint of the parts. In other words, when closed the cover will mate exactly with the sides of the outer casing 3 to provide a smooth unbroken finish on all sides of the lighter.

It will be understood from the above explanation that should the hinge between the casing and the cover 32 be damaged by rupture or breaking away of the hinge-ears 46, the hinge-joint may be readily repaired by replacement of the element 45 with a new part. That is to say, it is only necessary to remove the pin 50 by forcing or driving it out of its bearings in the holes 29 and 51, and also removing the hinge-pin 52, whereupon the hinge-element 45 may be withdrawn from under the edges of the ears 28. The damaged part may then be discarded and a new hinge-element 45 inserted in its place by reversing the operation and replacing the pins 50 and 52.

As before stated, Fig. 7 illustrates a cylindrical fuel-container or reservoir 4 for use with table lighters, it being noted that a rectangular boss 55 formed on its top wall provides for applying a windscreen 18 and hinge-element 45 thereto in the same manner as described in connection with the pocket lighter shown in the other views.

It will be observed from the foregoing specification that the present invention provides an ingenious and simple form of construction for mounting the parts of a hinge-joint for lighters to allow replacement of the elements when wear or accidental rupture renders them damaged. Moreover, the improved construction and method of mounting the parts of the device make for economy in the cost of manufacture of the lighter by the elimination of screws, studs and soldered connections. Consequently, the lighter may be manufactured at reduced cost to render it merchantable at a relatively low price. At the same time the complete article presents a neat and finished appearance without obtrusive mechanical parts visible to mar its ornamental appearance.

While the device is herein illustrated and described as embodied in a preferred form of construction, it is to be understood that variations may be made in the structure and arrangement of its parts without departing from the scope of the appended claims. Therefore, without limiting myself in this respect, I claim:

1. In a lighter of the type indicated comprising a hollow casing having a substantially flat top; a windscreen on the

5

top of said casing formed with vertical walls having integral ears projecting therefrom in spaced parallel relationship, a cover having a hinge-member thereon, a hinge-element for connecting said hinge-member on the cover to said casing, said hinge-element having a portion engageable between the lower portion of the ears on said wind- 5  
screen and the top of the casing, ears on said hinge-  
element disposed in abutting relation to the ears on the  
windscreen, and a pin inserted through holes in the ears  
on the windscreen and the abutting ears of the hinge- 10  
element to fixedly mount the hinge-element on said casing  
in position for connection to said hinge-member on the  
cover.

2. In a lighter for cigarettes and cigars, a casing having  
a substantially flat top, a member surmounting the top 15  
of the casing and formed with a pair of integral vertical  
ears spaced above the top of the casing to provide a  
horizontal slot therebetween, a hinge-element having a  
bottom portion slidably received in the slot beneath said  
ears, said hinge-element constructed with vertical ears 20  
disposed in abutting relation to the first-named ears, re-  
leasable means connecting the pairs of abutting ears for  
fastening the hinge-element rigidly in place on the casing  
while adapting it to be removed therefrom for repair or  
replacement, a cover for the casing, and means on the  
cover for pivotally connecting it to said hinge-element on  
the casing.

3. A cigar or cigarette lighter comprising a hollow cas-  
ing for fuel constructed with a substantially flat top, a  
walled member surmounting said casing with its bottom 30  
wall fastened to the flat top thereof and formed with  
opposed ears projecting upwardly therefrom in parallel  
spaced relationship, said ears having their bottom edges  
spaced above the flat top of said casing to provide a slot  
therebetween, a hinge-element having a flat bottom wall 35  
inserted in said slot beneath the ears of said walled mem-  
ber and formed with upstanding spaced ears abutting the  
ears on said walled member, a pin inserted through alining  
holes in said ears on the walled member and the ears on  
the hinge-element to fasten the latter to the casing while 40  
adapting it to be removed therefrom for repair or re-  
placement, a cover for the top of the casing, and means on  
said cover for pivotally connecting it to the hinge-element  
on the casing.

4. A lighter for cigarettes and cigars comprising a hol- 45  
low casing for fuel having a substantially flat top, a  
walled windscreen fixedly secured to the top of said  
casing, said windscreen constructed with a pair of inte-  
gral upstanding ears projecting from its wall with their

6

bottom edges spaced above the top of the casing to pro-  
vide a slot therebetween, a hinge-element having a bot-  
tom portion inserted in said slot and formed with up-  
standing ears in abutting engagement with the aforesaid  
ears on the windscreen, a removable pin projecting 5  
through alining holes in the ears on the windscreen and  
the ears on the hinge-element to releasably attach the  
latter to the casing, a cover for the casing, and inter-  
engaging means on said cover and hinge-element for piv-  
otally connecting the cover to the casing.

5. A lighter for cigarettes and cigars comprising a  
casing having a substantially flat top, a structure sur-  
mounting said casing and constructed with a pair of  
opposed integral ears with portions thereof spaced above 15  
the top of said casing to provide a relatively narrow hori-  
zontal slot therebetween, a hinge-element having a bottom  
portion inserted in said slot to mount it on said casing and  
formed with a pair of upstanding ears disposed in abut-  
ting engagement with said first-named ears, a removable 20  
pin projecting through alining holes in the abutting ears  
aforesaid for attaching said hinge-element fixedly in  
place on said casing, a cover for the top of said casing,  
and interengaging means on said cover and hinge-element  
for pivotally connecting the cover to the casing.

6. A lighter for cigarettes and cigars comprising a  
casing having a substantially flat surface on its top, a  
member surmounting said casing with portions thereof  
spaced above its flat surface to form a slot therebetween,  
said member having integral portions arranged in spaced 30  
parallel relationship and pierced with alining holes, a  
hinge-element having a portion thereof inserted into the  
slot between said member and the flat surface on the  
casing with other portions thereof engaging against the  
pierced portions of said member and pierced with holes  
alining with the aforesaid holes therein, a removable pin 35  
inserted through said alining holes for securing said  
hinge-element in place on said casing, a cover for the  
top of said casing, and cooperating means on said cover  
and said hinge-element for pivotally connecting the cover  
to said casing. 40

## References Cited in the file of this patent

## UNITED STATES PATENTS

1,146,555	Conrath	July 13, 1915
2,881,608	Lockwood	Apr. 14, 1959

## FOREIGN PATENTS

986,102	France	July 27, 1951
---------	--------	---------------