

Aug. 20, 1957

G. W. OWEN

2,803,123

PYROPHORIC LIGHTER

Filed Jan. 16, 1956

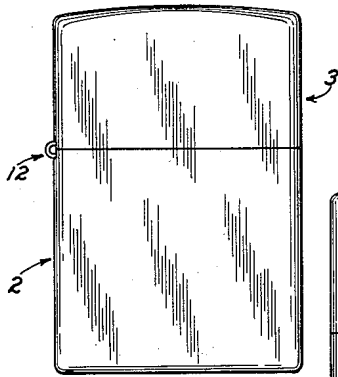

Fig. 1.

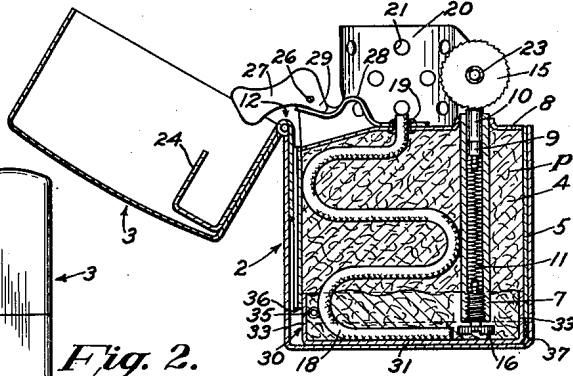

Fig. 2.

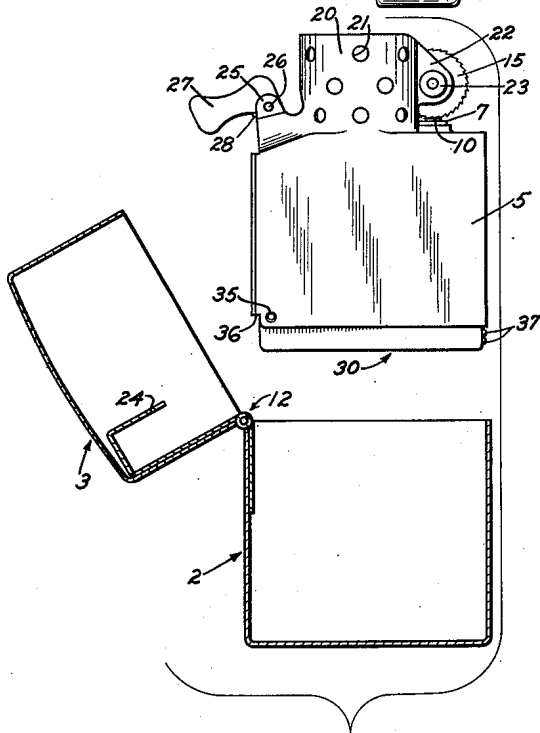

Fig. 3.

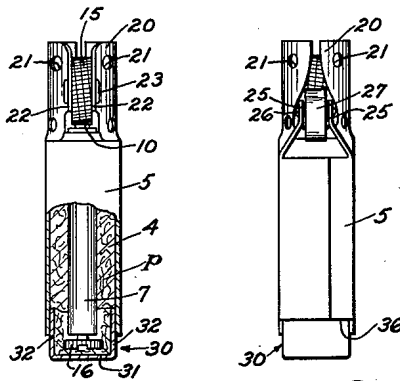

Fig. 4.

Fig. 5.

Fig. 6.

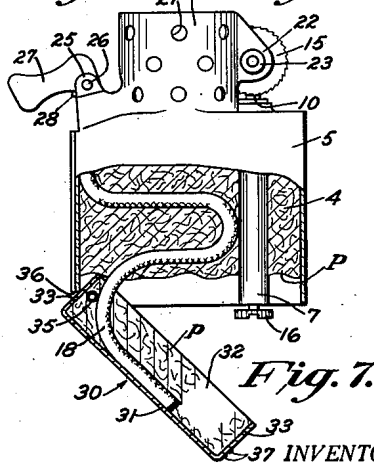

Fig. 7.

INVENTOR:
George W. Owen

BY
Princeton White
ATTORNEYS.

1

2,803,123

PYROPHORIC LIGHTER

George W. Owen, North Attleboro, Mass., assignor to Zippo Manufacturing Company, Bradford, Pa., a corporation of Pennsylvania

Application January 16, 1956, Serial No. 559,441

1 Claim. (Cl. 67—7.1)

This invention relates to pocket cigar and cigarette lighters embodying a wick immersed in inflammable liquid with means for igniting its end by the generation of sparks from a flint engaged by an abrasive disk or wheel.

One object of the invention is to provide means for sealing the fuel-chamber to prevent the escape of the liquid therefrom and more particularly to prevent evaporation of the highly volatile liquid.

Another object of the invention is to provide a small compact device of the type indicated having a hinged closure for the fuel-chamber which fits snugly within the filling opening yet is convenient for manual manipulation to open and close the chamber or reservoir.

Further objects of the improvement are set forth in the following specification which describes a preferred form of construction of the improved lighter as illustrated by the accompanying drawing. In the drawing:

Fig. 1 is a side elevational view of the present improved lighter enclosed in an outer housing or casing;

Fig. 2 is an end view of the same;

Fig. 3 is a composite view showing the lighter unit removed from its casing;

Fig. 4 is a transverse sectional view through the center of the lighter showing the elements in the interior thereof;

Fig. 5 is a part-sectional end view of the lighter;

Fig. 6 is a similar end view viewed from the opposite side; and

Fig. 7 is a part-sectional view of the lighter unit showing the hinged door or closure for the open bottom of the fuel-chamber in open position.

The present improved lighter is generally of conventional construction comprising an inner casing for containing the fuel, wick and a flint with a rotatable abrasive wheel for striking sparks from the flint to ignite the end of the wick. Lighters of the present type are generally adapted to fit within an outer housing or casing 2 such as shown in Fig. 1 of the present drawing. The casing 2 may be of precious metal or plated therewith with a smooth outer surface for ornamentation by engraving if desired and having a cap or cover 3 hinged thereto at 12 to be opened as shown in Fig. 4 for exposing the operating elements.

As shown in this latter view, the lighter unit comprises a fuel-chamber 4 formed by a casing 5 of the general shape of the outer casing 2 to adapt it to fit closely therewithin. Supported within the casing 5 is a vertical tube 7 projecting through the upper wall 8 of the casing to adapt it to hold cylindrical flints 10 of usual form. A helical spring 11 within the tube 7 engages a slidable plunger 9 for forcing the flint element upwardly to engage its end against the serrated periphery of a rotatable disk or wheel 15 for striking sparks from the flint. A thumb-screw 16 threaded into the bottom of the tube 7 provides for applying the force of the spring 11 to maintain pressure of the flint 10 against the periphery of the wheel 15. A wick 18 contained in the fuel-chamber 4 has its end inserted through an eyelet 19 fixed in an aperture in the upper wall 8 of the casing 5.

2

A cylindrical wall 20 projecting upwardly from the top of the casing 5 may be provided as a wind-screen to guard the flame and, as usually constructed the wall 20 is perforated with a plurality of apertures 21 to allow the air to enter therethrough. Ears 22 formed on the side of the wind-screen wall 20 serve as a mounting for the abrasive wheel 15 which is journaled on a tubular spindle 23 held in holes in the ears and riveted over at their ends (Fig. 5). On the opposite side of the wall 20 lugs 25 project upwardly from the top of the casing 5 for mounting a crosspin 26 on which is pivoted a latch 27 for holding the hinged cover 3 of the casing 2 closed or open. A leaf-spring 28 of undulatory shape fastened to the top wall 8 of the casing 5 by the eyelet 19, which is riveted through the wall, has its outer free end bearing against a projection or toe 29 adjacent the pivoted end of the latch 27 as shown in Fig. 4. Normally, when the cover 3 of the outer casing 2 is swung open on its hinge 12 the latch 27 is pivoted into the position shown in Figs. 3 and 4. When, however, the cover 3 is closed, a hooked member 24 fastened therein will be engaged with the latch 27 to pivot it clockwise and cause the spring 28 to yieldingly hold the latch for retaining the cover closed.

The above-described construction and arrangement of the elements of the lighter are generally similar to the disclosure in U. S. Letters Patent No. 2,517,191 of August 1, 1950 relating to a well-known type of lighter called "Zippo."

The present improvement consists in a novel and ingenious means for closing the mouth or opening in the bottom of the fuel-chamber 4 to eliminate leakage of the fluid therefrom, and more particularly to effectually seal the opening to prevent rapid loss of the fluid by evaporation. It has been the experience with previous types of lighters, particularly pocket lighters, that frequent refilling for replenishment of the fuel is necessary to maintain an adequate supply for repeated operations of the device. That is to say, it is a common complaint and criticism of cigar and cigarette lighters of usual construction that after they are carried for a short period they fail to operate due to lack of fuel for impregnating the wick. To overcome this defect or deficiency in lighters of previous construction, the present invention provides an effective seal for the closure of the filling opening in the fuel-chamber and at the same time renders it especially convenient for opening and closing the opening.

The bottom of the casing 5 is completely open across its length and width and the present invention provides a hinged closure-member 30 for closing it with a multiple sealing effect. The closure 30 is of the same general hollow shape in plan view as the casing 5, being constituted by a bottom wall 31, upstanding side walls 32 and end walls 33 (Fig. 7). Together these walls form a relatively shallow pan-like container which may be filled with cotton waste, felt or other absorbent material. One end of the closure 30 is pivoted on a crosspin 35 riveted through holes in the side walls of the casing 5 and one end wall of the casing 5 cut away slightly at 36 to allow the closure to swing back thereagainst, thereby acting as a stop to retain it in open position. The closure 30 is accurately dimensioned and shaped to adapt it to slide into the opening with its sides and ends fitting snugly against the interior of the side and ends of the casing 5. In this way the fuel-chamber 4 is closed and sealed against leakage of the liquid fuel, and further and most important, to prevent insinuation of air to cause rapid evaporation of the volatile liquid. A pair of small projecting ledges 37 embossed on the outside of the end wall 33 of the closure member 30 serves as means for engaging it with the finger nail to swing it downwardly for opening the bottom of the casing 5. As shown in Figs. 4 and 7, both the interior of the fuel-chamber 4 and the space in the closure 30 may

be packed with cotton waste, felt or other absorbent material *p* for maintaining the liquid fuel in suspension surrounding the wick 18 to impregnate it with the liquid.

For filling the fuel-chamber 4 the hinged closure 30 provides greater convenience and less chance of spillage when it is opened as shown in Fig. 7. By turning the lighter into a generally inclined position the liquid fuel may be readily supplied thereto by inserting the spout of the container into the fuel-chamber 4 to saturate the packing *p* and also saturating the packing in the closure 30 in which a portion of the wick is placed so that there is less chance of the fluid dripping or escaping at the top through the openings for the wick. After filling the device with liquid fuel the closure 30 is swung back and forced into closed position as shown in Fig. 4 being held closed by the frictional contact of its sides with the sides of the casing 5. With the cover 3 of the outer casing 2 open as shown in Fig. 3 the lighter unit may be slid into the housing to cause the closure 30 to seat against its bottom wall, thereby forming a double seal for the fuel-chamber as shown clearly in Fig. 4.

By reason of the present novel and ingenious construction of the closure for the opening in the fuel-chamber it has been demonstrated that leakage by capillary action and evaporation of the volatile liquid fuel is practically eliminated so that one charge of fuel will last many times longer without replenishment than with most lighters previously used. Moreover, the inconvenience and annoyance from failure of the device to function due to lack of fuel is avoided to render the lighter more reliable for repeated operations during extended periods of use. As a further advantage of the improved sealing means for the fuel-chamber the lighter remains cleaner without collecting fuel on the outside of the casing and thus it is rendered safer against accidental fires.

While the device is herein shown and described as embodied in a preferred form of construction, it is to be

understood that various modifications may be made in the structure and arrangement of its parts within the scope of the invention as expressed in the accompanying claim. Therefore, without limiting myself in this respect,

I claim:

In a cigar and cigarette lighter comprising a casing having a fuel-chamber therein, a wick mounted in said chamber for immersion in the liquid fuel contained therein and protruding above said chamber, a flint supported by the casing above said chamber, and abrasive means for engaging said flint to emit sparks for igniting the end of said wick, the combination comprising an opening in the bottom of said chamber for filling it with fuel, a closure of considerable depth hinged to the casing at the side of the opening therein and constructed and arranged with its sides dimensioned to fit snugly within the walls of said casing to hold it in closed relationship to seal the opening against loss of liquid fuel by leakage or evaporation, and an outer casing closely fitting said first named casing containing the fuel-chamber with the closure for the opening therein seated against the bottom wall of said outer casing to provide a double seal for the bottom opening in the inner casing, an opening in the top of said outer casing for insertion of the inner casing, and a cover hinged to the side of said outer casing and constructed and arranged to close down against the opening in the top of the outer casing to entirely enclose and protect the parts projecting above the inner casing.

References Cited in the file of this patent

UNITED STATES PATENTS

2,451,515 Simon et al. ----- Oct. 19, 1948

FOREIGN PATENTS

10,826 Great Britain ----- Dec. 5, 1912
1,046,420 France ----- July 8, 1953