

Nov. 7, 1950

P. B. MILLER

2,529,094

CIGARETTE LIGHTER ASSEMBLY

Filed Aug. 1, 1949

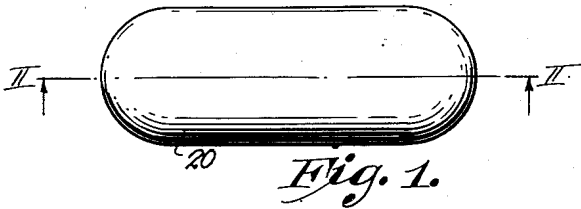

Fig. 1.

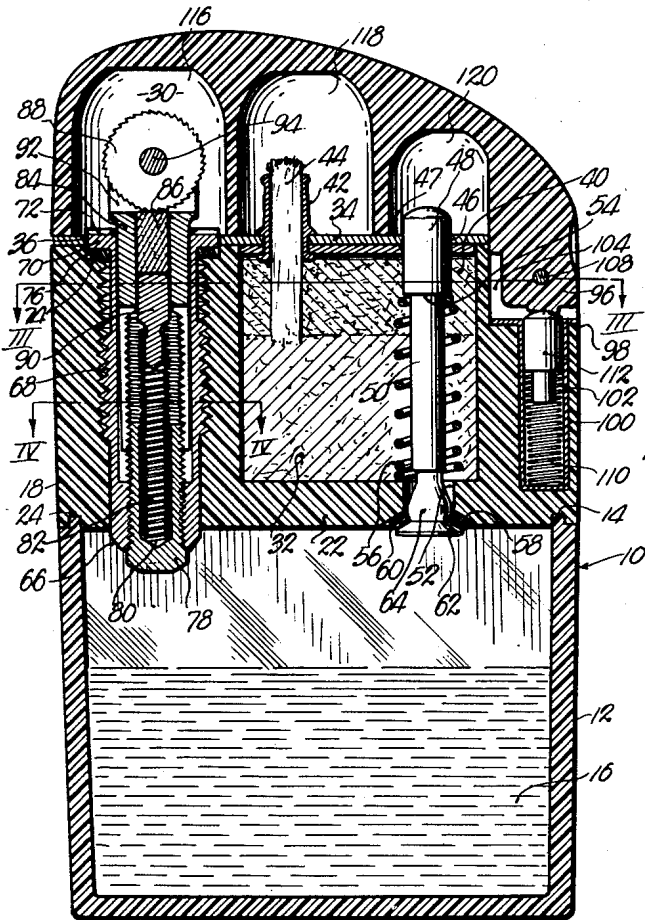

Fig. 2.

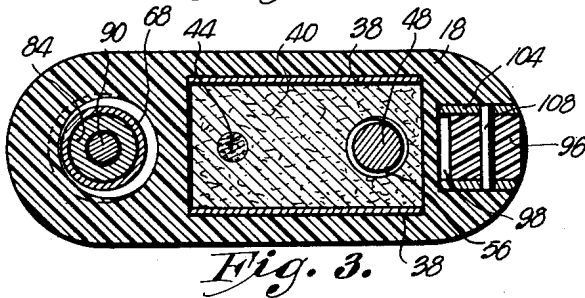

Fig. 3.

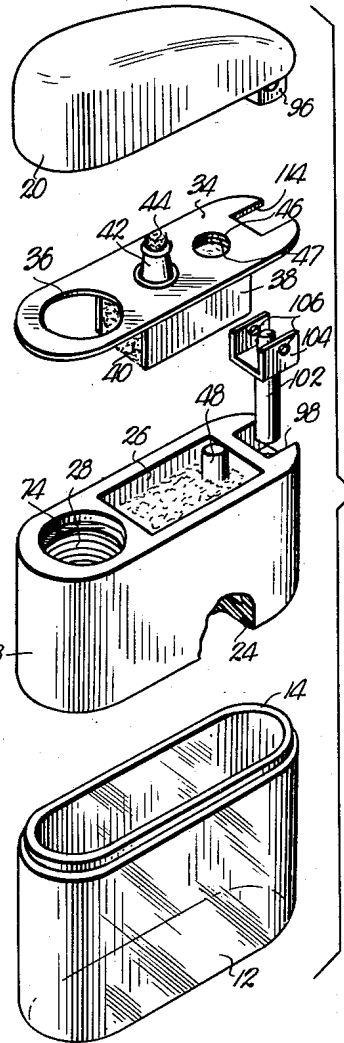

Fig. 4.

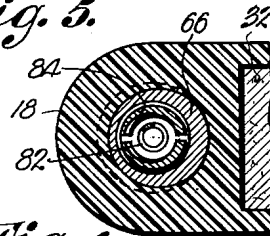

Fig. 5.

INVENTOR.
Price Bland Miller
BY *Carl Hovey*
ATTORNEY.

UNITED STATES PATENT OFFICE

2,529,094

CIGARETTE LIGHTER ASSEMBLY

Price Bland Miller, Kansas City, Mo., assignor to
Miller Liter Company, Kansas City, Mo., a cor-
poration of Missouri

Application August 1, 1949, Serial No. 107,866

5 Claims. (Cl. 67—7.1)

1

This invention relates to cigarette and cigar lighters and has for its primary object the provision of a casing made from transparent material permitting the user to know at all times when the supply of fuel therefor needs replenishing and the provision of manually operable means for saturating a wick compartment forming a part of the lighter with the fuel only when desired and when the same becomes necessary.

The most important object of the present invention is to improve upon the lighter constructions forming the subject matter of my co-pending application, Serial No. 700,310, filed September 30, 1946, now Patent 2,515,092, issued on July 11, 1950.

Another important object of the present invention relates to the construction of the cigarette lighter housing itself including the arrangement of the various chambers and compartments therein, all for the purpose of presenting an efficient, positively operating and inexpensive construction.

A further object of the present invention is to provide a cigarette lighter having a specially formed valve construction capable of being manually operated exteriorly of the housing and having a form that will positively prevent leaking of the fuel from the tank therefor into the wick compartment except when the valve is opened.

A still further object of the present invention relates to the way in which the inlet opening for the fuel compartment for the casing is closed by the flint assembly, the latter being entirely removable from the case not only for the purpose of filling the lighter with fuel, but for replenishing the flints as the same become necessary.

Other objects relate to details of construction including the particular form of the flint assembly; the manner in which the top wall of the lighter is removably mounted; and the way in which a swingable lid is provided for the lighter that completely encloses the top wall thereof and encloses the valve plunger, the wick and the friction wheel of the lighter when the lid is in a closed position.

In the drawing:

Fig. 1 is a top plan view of a cigarette lighter assembly made in accordance with my present invention.

Fig. 2 is a substantially central vertical cross-sectional view taken on line II—II of Fig. 1.

Fig. 3 is a transverse, cross-sectional view taken

2

on line III—III of Fig. 2 looking in the direction of the arrows.

Fig. 4 is a fragmentary, detailed, cross-sectional view taken on line IV—IV of Fig. 2; and

Fig. 5 is a stretched-out perspective view showing the component parts of the lighter.

One of the inherent defects of conventional cigarette lighters is the inability of the user of knowing precisely when the fuel supply thereof must be replenished. Secondly, in such conventional lighters, the wick compartment and the absorbent material therein are normally filled with the fuel. Consequently, particularly when the lighter is initially filled with fuel, leakage occurs and the wick becomes so fully saturated that much of the fuel is lost and oftentimes covers the entire exterior of the lighter itself.

It is also desirable that all parts of the lighter become completely enclosed when the same is not in use and, therefore, these important objects, as well as others, are attained by the lighter about to be described.

A body, broadly designated by the numeral 10, is shown completely assembled in Fig. 2 of the drawing and the various parts thereof are clearly illustrated in Fig. 5.

Body 10 includes a fuel compartment 12 that is molded or otherwise formed into an unitary structure open at its top and provided with a continuous up-standing flange 14 at its uppermost edge.

Fuel compartment 12 is preferably oval-shaped in cross-section for purposes of convenience in handling and in carrying in pockets and purses.

It is contemplated that the entire body 10 be made from a relatively light material such as plastic and that at least the fuel compartment 12 be fully transparent to the end that the supply of fuel 16 therewithin can always be seen by the user. A centermost section 18 of the body 10 is, however, preferably formed from translucent material as is a lid section 20. For purposes of attractiveness however, the lid 20 may be made from materials differing from that of sections 12 and 18 such as a metal substance or other opaque material. Similarly, the section 18 may be entirely opaque if desired.

The section 18 of the case or housing 10 is provided with a bottom wall 22 that serves as a normally horizontal partition for the case 10 when the various sections thereof are in the assembled condition. Sections 12 and 18 are interconnected with the partition wall 22 entirely covering the open top of fuel compartment 12,

the bottom wall 22 of the centermost section 18 being provided with a continuous groove 24 for receiving the up-standing flange 14 of fuel compartment 12. To the end that the compartment 12 is rendered liquid-tight, a press-fit between flange 14 and groove 24 is contemplated, together with a suitable fusing or adhesion of flange 14 in groove 24. The centermost section 18 of the case 10 is provided with an open top wick compartment 26 having the partition wall 22 as the bottom thereof and an internally tapped bore 28 next adjacent the compartment 26 for receiving a flint assembly broadly designated by the numeral 30.

The bore 28 is open at its top and bottom, thereby presenting an inlet opening for the compartment 12 and permitting pouring of the fuel 16 thereinto when the assembly 30 is removed from bore 28 as illustrated in Fig. 5.

The compartment 26 is provided with a filling of absorbent material 32 that terminates below the uppermost open end of compartment 26 as shown in Figs. 2 and 5. A top wall or plate 34 is provided for the section 18, said plate being elongated and conforming to the cross-sectional contour of the body 10 and being provided with a circular opening 36 adjacent one end thereof for clearing the flint assembly 30.

The top wall 34 has an U-shaped member 38 depending from the lowermost face thereof made from any suitable resilient material. The member 38 is adapted to fit within the uppermost end of the compartment 26 with the legs thereof extending thereinto and bearing tightly against the proximal side walls of compartment 26. The ends and the bottom of the member 38 are open and such member 38 yieldably holds a filling 40 of absorbent material having a slightly greater density than the material 32. The member 38 is held in place and attached to the top wall 34 by means of a short up-standing tube 42 adapted to receive an elongated wick 44 that extends downwardly through the material 40 and into the material 32 when the top plate 34 is in place in covering relationship to the body section 18.

Top wall 34 is also provided with an opening 46 on that side of wick 44 opposite to the opening 36 in register with an opening 47 in the bight of member 38 for clearing head 48 of an elongated reciprocable plunger 50 that extends downwardly through the materials 40 and 32 and terminates at its lowermost end within the wick compartment 12.

Partition 22 has an opening 52 in alignment with the openings 46 and 47 for clearing the lowermost end of plunger 50. The lowermost end of the head 48 presents a shoulder 54 for receiving the uppermost end of a spring 56 that is coiled about the plunger 50 and bears at its lowermost end upon the uppermost face of partition 22 within wick compartment 26. The lowermost end of the opening 52 in partition 22 has an outwardly flared seat 58 for receiving a washer-like valve 60 of resilient material that circumscribes the lowermost end of the plunger 50. This end of plunger 50 is specially formed to hold the valve 60 in the position illustrated in Fig. 2 and in conformity with the contour of the valve seat 58. To this end, plunger 50 has an outwardly flared flange portion 62 and a bulb-shaped portion 64, said portion 64 also serving to hold the valve 60 against upward movement on plunger 50. It is seen that valve 60 is normally held in the closed position with respect to opening 52 by the action of spring 56 and that the fuel 16 will not flow into

the wick compartment 26 except by downward manual movement of plunger 50 by the operator pushing upon head 48. A relatively tight sliding fit between the head 48 and the openings 46 and 47 prevents liquid seepage to the uppermost face of wall 34.

The flint assemblies 30 includes an elongated tubular member 66 slightly longer than the bore 28 within which it is disposed and having external threads 68 that mesh with the internal threads of bore 28 when the assembly 30 is in place. The uppermost end of the tube 68 is provided with an out-turned flange 70 having a kerf 72 for permitting removal of the assembly 30 as desired. The body section 18 is provided with an outwardly facing shoulder 74 adjacent the uppermost end of bore 28 for receiving a gasket 76 that underlies the flange 70 of tube 66.

A plug 78 is threadably mounted in the lowermost end of the tube 66 and is provided with a longitudinal cavity 80 open at its uppermost end for receiving an elongated coil spring 82. A second tubular member 84 is telescoped into the uppermost end of the tube 66, tube 84 being open at its bottom and split into a pair of substantially semi-circular halves as shown in Figs. 2 and 4.

Tube 84 is internally threaded at its lowermost end for receiving the uppermost threaded end of plug 78. The uppermost end of the tube 84 slidably receives flint 86 that is yieldably held against a friction wheel 88 by means of a follower 90 that is received by the uppermost end of the spring 82. In addition to being held in place by the plug 78, tube 84 is held in the tube 66 by a press-fit that is enhanced by the split ends thereof bearing against the innermost walls of tube 66 by the inherent resiliency of the material from which tube 84 is formed. The uppermost end of the tube 84 is bifurcated, one leg 92 being shown in Fig. 2 of the drawing for receiving the friction wheel 88 therebetween that is in turn journaled on a shaft 94.

The lid 20 of case 10 is designed to completely cover the uppermost face of the top wall 34 and is provided with a downwardly extending boss 96 adjacent one end thereof that is received by a cavity 98 in the body section 18. Cavity 98 is at one end of the section 18 opposite to the bore 28 and an opening 100 formed in section 18 in registering relationship with the bottom wall of cavity 98, receives a tube 102 by a press-fit.

The uppermost end of the tube 102 has a U-shaped bracket 104 thereon with the legs thereof provided with openings 106 for receiving a shaft 108 that passes through the boss 96 of lid 20. Tube 102 has a coil spring 110 therein for holding a pin 112 biased upwardly against the proximal lowermost end of the boss 96. Accordingly, pin 112 and spring 110 yieldably hold the lid 20 in the closed position shown in Fig. 2 as well as in an open position when the lid 20 is swung on pivot pin 108 to expose the uppermost face of wall 34 and the parts thereon.

Top wall 34 is provided with a notch 114 for clearing the boss 96 of lid 20. Lid 20 is provided with cavities or recesses 116, 118 and 120 for clearing the friction wheel 88, the wick 44 and the head 48 respectively. The lowermost face of the lid 20 rests flatly upon the wall 34 when lid 20 is in the closed position shown in Fig. 2, thereby completely enclosing all of the upstanding parts on wall 34.

It is apparent from the foregoing that the lighter is placed in use by swinging the lid 20 to an open position and actuating the wheel 88

to project particles of flint 86 toward the wick 44. The flame may be either blown out or extinguished by the closing of lid 20 as desired. When the wick 44 becomes dry, the operator merely presses downwardly upon the head 48 of plunger 50 to open valve 60 and thereupon tips the entire lighter to permit the fuel 16 to flow through opening 52 and into the fuel compartment 26 to saturate materials 32 and 40 as well as the wick 44.

When the supply of fuel 16 becomes low, the operator merely removes the entire assembly 30 by use of a tool or coin in the slot 72. The entire tube 66, together with the tube 84 and plug 78 can then be removed from the bore 28 and the fuel poured into bore 28. When assembly 30 is without the bore 28, the operator may remove the plug 78, spring 82 and follower 90 to replace flints 86. It is apparent that at no time will there be excess fuel on the exterior of the lighter or adjacent the uppermost face of wall 34 because the operator may predetermine the amount of fuel 16 that is permitted to flow into the wick compartment 26.

The entire lighter may be made extremely attractive by varying the colors of the various sections 12, 18 and 20 and in all respects the lighter is light, handy, simple to use and maintain and completely devoid of bulkiness.

It is also manifest that the lighter forming the subject matter hereof is capable of many changes and modifications and accordingly, it is desired to be limited only by the spirit of the invention as contemplated by the accompanying claims.

Having thus described the invention, what is claimed as new and desired to be secured by Letters Patent is:

1. In a lighter of the kind described, a hollow, perforated case having a partition dividing the same into a fuel compartment and a wick compartment, said partition having an opening formed therein interconnecting the compartments; a valve normally closing said opening and movable to and from an open position; a reciprocable plunger connected with said valve and extending through said wick compartment and the perforation of said case to a point exteriorly of the case for moving the valve to said open position; a filling of loose, fibrous, absorbent material in the wick compartment; and a resilient holder on the top wall extending into the wick compartment and frictionally bearing against said wall thereof for holding the top wall in place and a relatively dense fibrous pad of absorbent material carried by said holder in circumscribing relationship to a portion of the wick in the wick compartment.

2. In a lighter of the kind described, a hollow case having a wall structure setting off a fuel compartment and a separate wick compartment, said wall structure having an opening formed therein interconnecting the compartments; a valve head normally closing said opening and movable into the fuel compartment to an open position from a place against the wall structure; a reciprocable plunger having a shoulder therein, said plunger being joined to said valve head and extending to a point exteriorly of said case for moving the valve head to said open position; a relatively dense fibrous pad of absorbent material mounted in the wick compartment in circumscribing relationship to the plunger adjacent said perforation for impeding escape of fuel thru the perforation as the plunger is reciprocated; and a spring coiled about the plunger entirely within

the wick compartment and having one end thereof bearing against the said shoulder and the opposite end thereof bearing against the opposite structure for yieldably holding the valve head in a closed position.

3. In a lighter of the kind described, a hollow case having a top wall, a bottom wall, a normally horizontal partition between the walls, presenting a fuel compartment between said partition and said bottom wall, and a normally vertical partition joining said top wall and the horizontal partition, presenting a wick compartment having a loose filling of fibrous, absorbent material therein, and a flint assembly compartment, said top wall and said horizontal partition each having a pair of spaced openings therein, one opening of the top wall and one opening of the horizontal partition registering with the wick compartment and having an elongated, reciprocable plunger extending therethrough; a valve on the plunger for said one opening in the horizontal partition, the other opening of the top wall and the other opening of the horizontal partition registering with said flint assembly compartment and having a flint assembly extending therethrough; flint supporting means forming a part of said assembly; a friction wheel carried by said supporting means exteriorly of said top wall; a wick extending through said top wall and into the said wick compartment between the plunger and the friction wheel; and a lid swingably to and from a position covering said top wall, said lid being provided with separate cavities for receiving each of said friction wheels, the proximal end of said wick and the proximal end of said plunger respectively.

4. In a lighter of the kind described, a hollow case having a top wall, a bottom wall, a normally horizontal partition between the walls, presenting a fuel compartment between said partition and said bottom wall, and a normally vertical partition joining said top wall and the horizontal partition, presenting a wick compartment having a loose filling of fibrous, absorbent material therein, and a flint assembly compartment, said top wall and said horizontal partition each having a pair of spaced openings therein, one opening of the top wall and one opening of the horizontal partition registering with the wick compartment and having an elongated, reciprocable plunger extending therethrough; a valve on the plunger for said one opening in the horizontal partition, the other opening of the top wall and the other opening of the horizontal partition registering with said flint compartment and having a flint assembly extended therethrough; flint supporting means forming a part of said assembly; a friction wheel carried by said supporting means exteriorly of said top wall; a wick extending through said top wall and into the wick compartment, said top wall being separate from the remainder of the case; a resilient holder on the top wall extending into the wick compartment and frictionally bearing against said walls thereof for holding the top wall in place; and a relatively dense fibrous pad of absorbent material carried by said holder in circumscribing relationship to a portion of the wick in the wick compartment.

5. In a lighter of the kind described, a hollow case having a top wall, a bottom wall, a normally horizontal partition between the walls, presenting a fuel compartment between said partition and said top wall and a normally vertical partition joining said top wall and the horizontal partition, presenting a wick compartment having a loose filling of fibrous, absorbent material therein, and

7

a flint assembly compartment, said top wall and said horizontal partition each having a pair of spaced openings therein, one opening of the top wall and one opening of the horizontal partition registering with the wick compartment and having an elongated, reciprocable plunger extending therethrough; and a valve head on the plunger for said one opening in the horizontal partition, the other opening of the top wall and the other opening of the horizontal partition registering with said flint assembly compartment and having a flint assembly extending therethrough, said flint assembly comprising a removably mounted tubular member, a tube having internal threads positioned in the upper portion of said tubular member, extending outwardly therefrom and having a flint and a flint wheel carried by the outwardly extending portion, a spring and follower assembly for urging the flint against the flint wheel, and an exteriorly threaded plug closing the inner end of the tubular member and in threaded engagement

with the internal threads of said tube, said plug and inner end of the tubular member being extended beyond the horizontal partition and into the fuel compartment.

8

PRICE BLAND MILLER.

REFERENCES CITED

The following references are of record in the file of this patent:

UNITED STATES PATENTS

Number	Name	Date
2,438,632	Bushman	Mar. 30, 1947

FOREIGN PATENTS

Number	Country	Date
79,997	Switzerland	June 18, 1938
100,850	Austria	Aug. 25, 1925
242,905	Switzerland	June 15, 1946
526,095	France	June 24, 1921
853,002	France	Nov. 18, 1939