

June 5, 1934.

L. V. ARONSON

1,961,577

FUELING ARRANGEMENT FOR PYROPHORIC LIGHTERS

Filed July 30, 1930

2 Sheets-Sheet 1

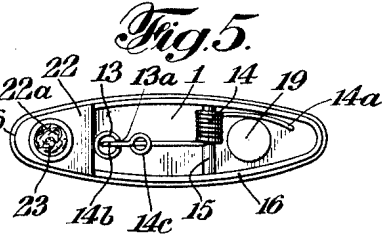
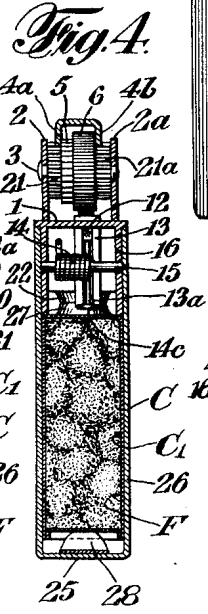
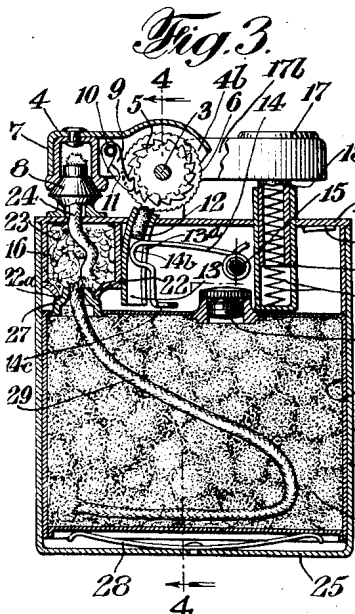
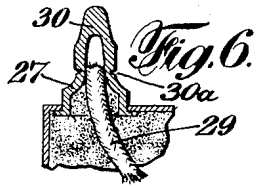
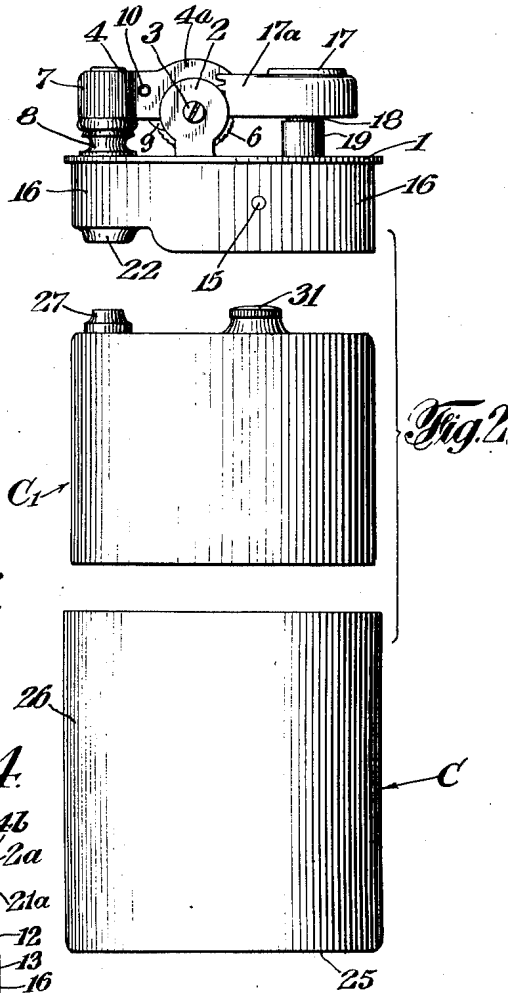
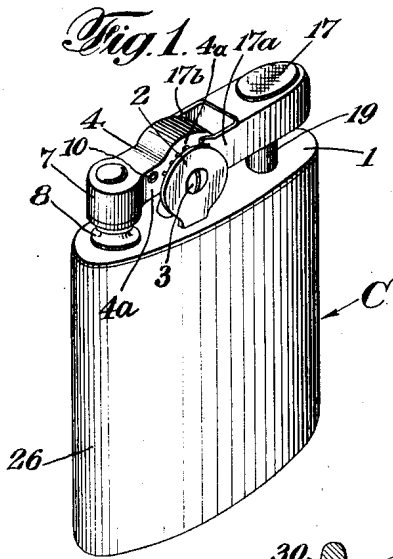

INVENTOR  
*Louis V. Aronson*  
BY  
*Ward, Crosby & Seal*  
ATTORNEYS

June 5, 1934.

L. V. ARONSON

1,961,577

FUELING ARRANGEMENT FOR PYROPHORIC LIGHTERS

Filed July 30, 1930

2 Sheets-Sheet 2

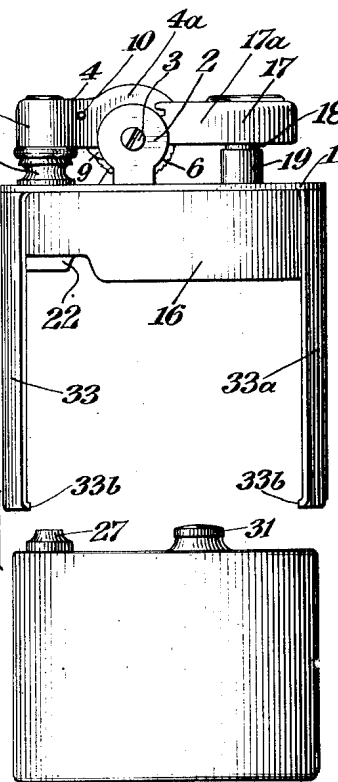
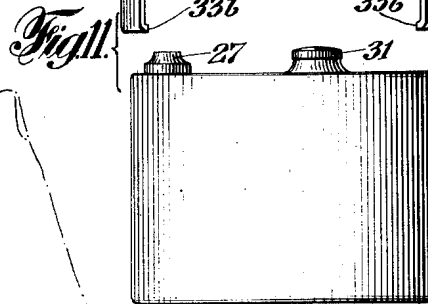
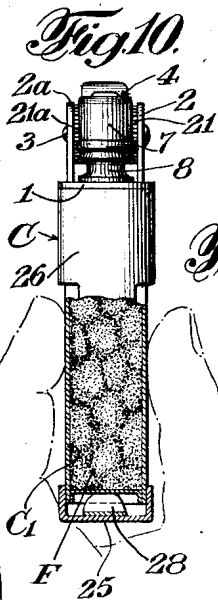
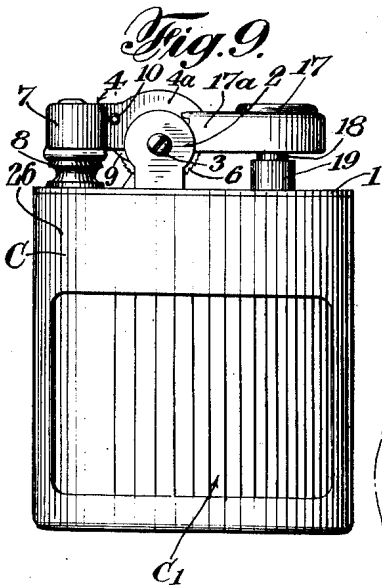
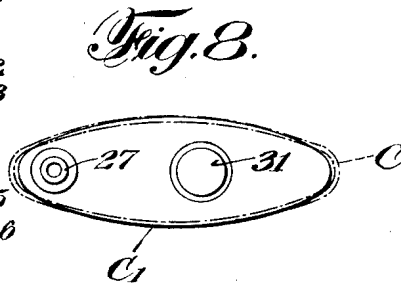
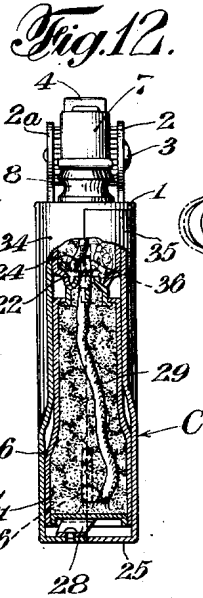
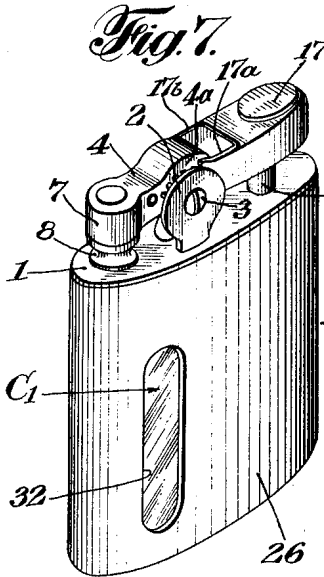

INVENTOR  
*Louis V. Aronson*  
BY  
*Ward, Crosby & Neal*  
ATTORNEYS

# UNITED STATES PATENT OFFICE

1,961,577

## FUELING ARRANGEMENT FOR PYROPHORIC LIGHTERS

Louis V. Aronson, Newark, N. J., assignor to Art Metal Works, Inc., Newark, N. J., a corporation of New Jersey

Application July 30, 1930, Serial No. 471,705

6 Claims. (Cl. 67—7.1)

My invention relates to fuel-feeding or fuel-supplying arrangements for pyrophoric lighters.

My invention also relates to fuel-containing casings or capsules of novel construction and arrangement.

My invention has further reference to a novel and highly efficient arrangement for supplying fuel to the wick of a pyrophoric lighter.

Various other objects, advantages and characteristics of my invention will become apparent from the following description taken in connection with the accompanying drawings.

My invention resides in the fueling arrangements, fuel-supplying combinations, fuel containers, and novel arrangements of the character hereinafter described and claimed.

For an understanding of my invention and for an illustration of some of the many forms thereof, reference is to be had to the accompanying drawings, in which:

Figure 1 is a perspective view of pyrophoric lighting mechanism;

Fig. 2 is a side elevational view showing various parts of my novel arrangement of Fig. 1 in disassociated relation;

Fig. 3 is a vertical sectional view, partly in elevation, of the lighting mechanism shown in Fig. 1;

Fig. 4 is a transverse vertical sectional view, partly in elevation, and is taken on the line 4—4 of Fig. 3 looking in the direction of the arrows;

Fig. 5 is a view looking at the bottom of the spark-producing mechanism shown at the top of Fig. 2;

Fig. 6 is a fragmentary vertical sectional view of a sealing arrangement for a fuel capsule;

Fig. 7 is a perspective view corresponding generally with Fig. 1 and showing a variation of my invention;

Fig. 8 is a plan view illustrating a casing relation in accordance with my invention;

Fig. 9 is an elevational view illustrating another variation of my invention;

Fig. 10 is a side elevational view, partly in vertical section, of the mechanism shown in Fig. 9;

Fig. 11 is a side elevational view showing in disassociated relation parts of another variation of my invention; and

Fig. 12 is an end elevational view, partly in section, of another form of my invention.

Referring to Figs. 1 to 5 inclusive, there is illustrated a plate or member 1 which may be oval, as shown, or of any other suitable configuration. Upstanding from the plate 1 are spaced standards or ears 2, 2a through which a pin or member 3 extends. A member 4 is pivoted for movement about an axis defined by the pin 3, said member 4 preferably having depending side walls 4a, 4b between which side-by-side

wheels 5 and 6 are rotatably disposed on said pin 3, said wheels being suitably secured together for rotatable movement as a unit. Carried by the member 4 at the otherwise free end thereof is a snuffer cap 7 which coacts with a wick tube 8 carried by and extending above the aforesaid plate 1, Fig. 3.

The aforesaid wheel 5 is formed with peripheral ratchet teeth with which a pawl 9 may coact, said pawl 9, preferably but not necessarily being pivoted on a pin 10 extending transversely between the side walls 4a, 4b and said pawl 9 being suitably biased toward and into engagement with the ratchet wheel 5, as by a spring 11, Fig. 3. The pawl 9 is utilized for actuation of the ratchet wheel 5 in a manner hereinafter described. However, in lieu of the disclosed pawl arrangement, it shall be understood that any other suitable arrangement may be utilized for actuating the ratchet wheel 5, or equivalent.

The aforesaid wheel 6 is exteriorly serrated or roughened on its peripheral face and with the latter there is coactable, for spark-producing purposes, a pyrophoric element 12 which may in part project from a tube 13 extending through the aforesaid plate 1. Any suitable arrangement may be utilized for biasing said pyrophoric element 12 into engagement with the serrated face of the wheel 6. As herein shown, there is thus utilized a spring 14 and a transverse pin 15, the latter, in the form of my invention herein shown, being supported in opposite walls of a skirt section 16 depending from and carried by the aforesaid plate 1. The aforesaid spring 14 may be coiled around the pin 15, one end of plate 1, said spring 14, adjacent its other end comprising a bowed section 14b disposed within the aforesaid tube 13, the latter being axially slotted as at 13a so that said spring section 14b is freely movable therealong. Adjacent the bowed spring section 14b, said spring 14 may terminate in an actuating section 14c. The bowed spring section 14b engages the lower surface of the pyrophoric element 12, said bowed section 14b, when positioned as shown in Fig. 3, tending to swing in a clockwise direction, due to the unwinding tendency of the spring, whereby the pyrophoric element 12 with considerable and the proper amount of pressure is held in engagement with the periphery of wheel 6.

Any suitable arrangement may be utilized for actuating the wheel 6 to cause it, by coaction with the pyrophoric element 12, to produce sparks for fuel-ignition or flame-producing purposes. To this end, there may be utilized a manually operable knob 17 having depending therefrom a member or stem 18 telescopically related to a cylinder or barrel 19 carried by and depending from the aforesaid plate 1. The stem 18

may be open at its bottom and the barrel 19 may be closed at its bottom whereby a suitable helical spring 20 may be utilized for biasing the stem 18 and knob 17 in an upward direction, Figs. 2 and 3. The knob 17 comprises spaced members 17a, 17b extending toward the pin 3, each of said spaced members being equipped with rack teeth, the respective sets of which mesh with pinions 21, 21a rotatable on the pin 3 and secured, in any suitable manner, to the aforesaid member 4 for pivotal or oscillatory movement therewith. As herein illustrated although not necessarily, the pinions 21, 21a are oscillatory with the member 4 because permanently meshed with arcuate, toothed segments of the respective side walls 4a and 4b in the manner described in my copending application Serial No. 440,213, filed March 21, 1930.

In accordance with the form of my invention herein disclosed, the aforesaid plate 1 carries a fuel chamber or compartment which, by preference is disposed beneath the wick tube 8 and which may be formed in any suitable manner. When the plate 1 carries a skirt section 16 as hereinbefore stated, it is desirable that a chamber-forming member 22 be inserted thereinto at one side thereof, said member 22 having angularly related sides, the marginal edges of which are soldered or otherwise secured to adjacent surfaces of the skirt section 16 to thereby form the aforesaid fuel chamber which preferably contains a mass 23 of cotton or other suitable absorbent material and which has disposed therein a wick 24 which extends upwardly through and terminates slightly beyond the wick tube 8. If desired, the member 22 may be soldered or otherwise suitably secured to the tube 13.

The fuel chamber described above is adapted to receive and contain fuel of any suitable character, such fuel preferably passing thereinto or being passed thereinto, as hereinafter described, through an opening 22a in the lower side of member 22, Fig. 3.

The plate 1 constitutes a supporting member for all of the parts hereinbefore described, these forming, as shown at the top of Fig. 2, a unitary device which may be utilized for spark-producing purposes. As thus illustrated in Fig. 2, the plate 1 may be held in one hand and the knob 17 depressed in opposition to the expansive tendency of spring 20 whereupon the hereinbefore described sets of rack teeth coacting, respectively, with the pinions 21 and 21a cause the member 4 to swing clockwise, Fig. 2, the pawl 9 coacting with the ratchet wheel 5 to impart a step of movement to the latter and also to the serrated wheel 6. Accordingly, the latter coacts with the pyrophoric element 12 to produce a shower of sparks which pass toward the now exposed upper end of the wick 24.

Upon release of pressure from the knob 17, the latter is elevated under the influence of spring 20 and the member 4 swings in a counter-clockwise direction, Fig. 2, until seated upon the wick tube 8. During this last named movement of the member 4, the pawl 9 idles with respect to ratchet wheel 5 and consequently the wheel 6 remains stationary.

In accordance with the form of my invention shown in Figs. 1 to 5 inclusive, the aforesaid plate 1 is adapted for detachable association with a casing C which per se may comprise a base 25 having upstanding therefrom side wall structure 26 which is open at its top, the

base 25 and wall structure 26 being formed integrally with each other or separately, as may be desired. With the form of my invention herein illustrated, the aforesaid skirt section 16 of the member 1 is adapted to be telescopically related to the casing C whereby the parts are maintained in assembled relation. Accordingly and as shown, the skirt section 16 should be of such exterior dimensions that it is slidable, in close-fitting, frictional relation, within the upper open end of the casing C, said skirt section 16 and the side wall structure 26 of casing C preferably being of oval configuration although this is not necessary. With the plate 1 thus detachably retained to the casing C, it results that the fuel chamber formed in part by the skirt section 16 is disposed within said casing C and, in accordance with my invention, fuel is introduced into said fuel chamber in any suitable manner.

This may be accomplished in a variety of ways. As herein shown, there is utilized a fuel-containing casing or capsule C1 which is received by the casing C and which is suitably disposed in fuel-transferring relation with respect to the fuel chamber within the skirt section 16.

As shown particularly in Figs. 2, 3 and 4, the casing C1 may, and preferably does, conform in exterior configuration with the interior configuration of the casing C whereby adjacent surfaces of the two casings come into relatively close-fitting relation although it is desirable that the casing C1 be slidable, in a relatively easy manner, within the casing C.

Carried by the top wall of the casing C1 is a wick tube or nozzle-forming structure 27 adapted to form a substantially sealed passage between the casing C1 and the hereinbefore described fuel chamber within the skirt section 16. To this end, said wick tube 27 is formed preferably as a nozzle which extends into the opening 22a of the member 22. For the purpose of maintaining the passage between the two fuel casings substantially sealed, it is desirable that the casing C1 be resiliently seated and, accordingly, there may be utilized a bowed spring 28 suitably secured to the interior bottom surface of casing C and contacting, adjacent its ends, with the lower surface of casing C1. Or, any other suitable seating arrangement may be utilized for the casing C1.

The casing C1 is adapted to contain fuel of any suitable character such, for example, as liquid fuel. Preferably, however, said casing C1 contains a suitable quantity of semi-solid or jelly-like fuel F such as described, for example, in the pending Proper application Serial No. 342,306, filed February 23, 1929.

Preferably, fuel is fed from the casing C1 into the chamber within skirt section 16 by wick action and, accordingly, said casing C1 may have therein a suitable wick 29 which extends through and projects partly beyond the aforesaid wick tube 27.

With the parts positioned as shown in Fig. 3, the operation is as follows:

The spring 28 biases the casing C1 in an upward direction so that the wick tube 27 seats as shown against the lower surface of member 22. Further, it is desirable that the arrangement be such that the upper wall of casing C1 is biased into engagement with the lower end of cylinder 19.

Accordingly, inflammable material passes from

80

85

90

95

100

105

110

115

120

125

130

135

140

145

150

the casing C1 into the fuel chamber within the skirt section 16. From the last named chamber, inflammable material is transferred, by the wick 24, to the ignition region where flame may be produced by the pyrophoric sparks emanating from the element 12 when the knob 17 is depressed.

It is my belief that the fuel chamber formed in part by the member 22 acts in a regulatory character on the inflammable material so that the latter passes more uniformly and not at an unduly rapid rate along the wick 24. More particularly, when the fuel F in the casing C1 is of jelly-like character, it appears that fuel exists in the chamber defined in part by the member 22 largely in a liquid state although some gaseous fuel is probably there as well.

In accordance with one phase of my invention, the casing C1 may be more or less permanently associated with the casing C and fuel may be introduced into said casing C1 in any suitable manner as desired. Ordinarily and preferably, however, the casing C1 is a refill casing and, hence, is discarded after the fuel is exhausted therefrom.

Assuming that the plate 1 has been detached from the casing C and that the latter is empty, the fuel-containing casing C1 of Fig. 2 may be disposed interiorly of said casing C and seated upon the spring 28. Thereupon, the skirt section 16 may be introduced into the upper open end of casing C until the parts come into the position shown in Figs. 3 and 4, the flanged section of member 1 beyond the skirt section 16 coming to rest upon the upper surface of the casing side wall structure 26. In so doing, the opening 22a of member 22 first receives the wick tube 27 and, after these parts are seated, the casing C1 is moved downwardly, Fig. 1, to some extent thereby placing the spring 28 under tension. In accordance with the form of my invention herein disclosed, the degree of frictional engagement between the skirt section 16 and the interior surface of the side wall structure 26 is sufficient to satisfactorily retain the parts positioned as illustrated in Figs. 3 and 4. Since, as stated, the spring 28 is under tension at this time, it results that the passage between the casing C1 and the casing containing the wick 24 is sealed or substantially so and, therefore, none or but little of the inflammable material escapes into the casing C.

It is intended that fuel-containing casings such as the herein described casing C1 shall be sold on the market and that the user of the lighting mechanism, when the fuel has been used from that fuel-containing casing then associated with his lighting mechanism, shall remove the plate 1 together with the thereby-carried parts from the casing C; thereupon, the therein-contained empty casing C1 together with the associated wick 29 may be discarded and a new duplicate casing purchased, the latter being filled with fuel and having a wick tube 27 through which an unused wick extends; the new fuel-containing casing C1 may then be inserted in the main casing C whereupon the plate 1 may be attached to said casing C1 in the manner heretofore described, all of the parts, as a matter of course, coming to their proper operative positions.

When refill casings are thus utilized, the provision of the fuel casing in part bounded by the member 22 is important aside from the reasons heretofore given because, ordinarily, some fuel

remains therein after exhaustion of the supply of fuel from the casing C1. Therefore, it results that the lighting mechanism is in condition for operation at any time.

The fuel-containing casing C1 as shown in Fig. 2 is ready for insertion in the casing C. When casings such as said fuel-containing casing C1 are sold on the market, it is desirable that the opening through any wick tube 27 be and remain closed until the casing C1 of that wick tube is to be inserted in a casing C. The opening through the wick tube 27, or equivalent, may thus be closed in any suitable manner. A preferred way, however, involves an arrangement somewhat similar to that illustrated in Fig. 6 wherein a cap member 30 is secured to and seals the wick tube 27. A channel 30a formed in the cap 30 leaves but a thin ridge of material which may readily be cut or severed when the fuel-containing casing is to be disposed in the casing C. However, in lieu of an arrangement such as illustrated in Fig. 6, it shall be understood that other equivalent or suitable closure arrangements may be utilized.

The fuel F may be disposed within the casing C1 in any suitable manner. It may be sealed therein somewhat the same as material is sealed into ordinary collapsible tube-like containers or, as shown, said casing C1 may be formed with an opening in its top wall, for example, through which the fuel is inserted and which is thereafter suitably closed, as by a threaded plug 31, Figs. 2 and 3. Obviously, in lieu of the arrangements just described, fuel may be introduced into the casing C1 in any other suitable manner.

An important advantage of refill fuel casings such as herein described resides in the fact that the user of the lighting mechanism obtains a new wick with each fresh supply of fuel. The wick 24 remains more or less permanently associated with the lighting mechanism, but, with refill casings, a new wick 29 is obtained each time that a new fuel-containing casing is inserted into the main casing. It is the wick 29 which coacts most directly with the jelly-like fuel and, therefore, it is this wick which is more apt to become clogged. However, by virtue of the arrangement just noted, the wick arrangement is satisfactory in practice.

When the pyrophoric element 12 becomes worn to such an extent that a new one is required, or when repairs are necessary, the plate 1 may be detached from the casing C whereupon the actuating sections 14c of spring 14 may be manipulated to permit removal of the worn pyrophoric element and substitution of a new one therefor. Thereafter, the plate 1 may readily be attached to the casing C to restore the lighter mechanism to operative condition.

Although the use of the disclosed construction involving the detachable plate 1 is desirable because opening the casing C for refill purposes and further, because exposing the pyrophoric element and its biasing mechanism for manipulation when a new pyrophoric element is required, it shall be understood that the invention is not limited to the utilization of a detachable plate 1 such as disclosed herein or one generally the equivalent thereof. This is true because other arrangements may be utilized for replacement of pyrophoric elements and also other arrangements may be utilized for gaining access to the main casing C so that a new refill casing C1 may be substituted for an empty one.

As hereinbefore stated, the use of semi-solid or jelly-like fuel F is desirable. It shall be understood, however, that refill casings C1 may contain liquid fuel rather than semi-solid or jelly-like fuel, if desired.

As will be noted from the drawings, the hereinbefore described spaced standard of ears 2, 2a are restricted in width where secured to the plate 1. An arrangement of this character is advantageous over prior art constructions because better exposing the serrated wheel 6 whereby the latter may more readily be cleaned.

The hereinbefore described fuel-containing casing or capsule C1 may be formed of any suitable material. Under some circumstances, it may be desirable to form said casing or capsule C1 of aluminum in sheet form. This is true particularly when it is desirable to avoid extra weight. Under other circumstances, it may be desirable to form said casing or capsule C1 of transparent or semi-transparent material, as glass, a phenol or other condensation product, celluloid preferably of the non-inflammable type, etc.

When said casing or capsule C1 is thus formed of transparent or semi-transparent material, an arrangement such as illustrated in Fig. 7 may be employed. In this case, the wall structure 26 of the casing C is provided with an elongated slot 32 whereby the level or quantity of the fuel within said casing or capsule may be determined at a glance. In lieu of the construction just described, any other suitable arrangement may be utilized for observing the quantity of fuel within the fuel capsule C1.

In Fig. 8, I have illustrated a variation of my invention. In this figure, the casing C is shown in plan and may conform with the casing C hereinbefore described. The refill or fuel-containing casing is also shown in plan and, as illustrated, it may be resting on or disposed directly above the casing C.

In accordance with this form of my invention, the two casings do not inherently take the same shape. In other words, the outside width of the casing C1 may slightly exceed the inside width of the casing C while the length of the casing C may slightly exceed that of the casing C1. Under such circumstances, it is necessary to slightly squeeze the casing C1 before it can be passed into the casing C. It results, therefore, particularly when the casing C1 is formed of resilient material, that there is a squeeze action by the casing C on the casing C1 and, due to this condition, fuel is passed or more readily passes from the casing C1 into the fuel chamber within the skirt section 16, or equivalent. While the arrangement above described is desirable under some circumstances, it shall be understood that my invention is not to be limited thereto.

Referring to Figs. 9 and 10, there is illustrated another variation of my invention wherein the casing C is apertured in a desired manner, as on one or both sides thereof, and functions therefore, as a frame. With such an arrangement, the casing or capsule C1 may be formed from material readily deformable by manual action whereby, as illustrated in Fig. 10, it may be squeezed to positively feed the fuel in a desired manner.

In connection with an arrangement such as shown in Figs. 9 and 10, the casing or capsule C1 may be formed of elastic material, if desired, so that it will return to the position shown after the squeezing action. Or, if desired, the aper-

tures of the casing C may be covered with suitable elastic material which will not interfere with the squeezing action but which will return to an original position after discontinuation of the squeezing action. Still further, if desired the casing C need not be apertured but may comprise in whole or in part a suitable elastic wall which returns to an original position after discontinuation of the squeezing action. The constructions last described are advantageous because the appearance of the device as a whole is not adversely affected by an exposed partly collapsed casing or capsule C1.

Referring to Fig. 11, I may utilize a skeleton frame formed by members 33, 33a depending from the aforesaid plate 1, or equivalent. These members may be resilient and provided with intumed toes 33b. Preferably, they are shaped so as to conform to the contour of the end surfaces of the casing or capsule C1. As will be obvious, the latter may readily be associated with the plate 1 together with the members 33, 33a, the latter firmly retaining said capsule C1 in its intended fuel-feeding position. In a ready manner, the capsule C1 may be detached when the supply of fuel therein is exhausted. An arrangement like that illustrated in Fig. 11 is desirably provided as an inexpensive construction and particularly the capsule C1 of Fig. 11 may be a lithographed metal container or the like utilizable for advertising or similar purposes.

Referring to Fig. 12, there is illustrated another form of my invention wherein the fuel-containing casing or capsule C1 is introduced into and removed from the casing C in a different manner from that heretofore described. As shown in said Fig. 12, the casing C, in effect, comprises a base section 34 and a cover section 35, said sections being pivoted together on suitable hinges 36 whereby the cover section 35 may swing sidewise with respect to the longitudinal axis of the casing C. The hinges 36 may be disposed at that end of the casing C most closely adjacent the knob structure 17, suitable latching mechanism, not shown, preferably being disposed at that end of said casing C most closely adjacent the wick tube 8 for detachably retaining the section 35 closed upon the section 34.

When it is desired to remove the capsule C1 from the casing C of Fig. 12, the cover section 35 may be swung upon the hinges 36 thereby opening said casing C and permitting ready removal of the capsule C1 after slight depression thereof against the action of spring 28.

In as simple a manner, a new filled capsule C1 may be substituted for that capsule just discarded. This is accomplished merely by retaining the cover section 35 in open position and inserting said filled capsule C1 sidewise into the section 34, said capsule C1 being initially pressed downwardly against the spring 28 so that the tube 27 may be brought within the opening 22a at the lower end of member 22. Thereupon, the capsule C1 may be released and the cover section 35 swung to closed position. With the various parts thus related, fuel passes from the capsule C1 to the fuel chamber containing the wick 24 in the same manner as heretofore described.

Arrangements constructed in accordance with my invention are highly efficient in operation. There is little or no evaporation or other loss of fuel and, moreover, the fuel comes to the

upper end of wick 24 at a proper or satisfactory rate. Consequently, a given charge of fuel or a single capsule C1 lasts for a long period of lighter operation, it being unnecessary to replenish the fuel supply nearly as frequently as with the usual prior arrangements.

Added to the foregoing are the advantages obtained by using a supply of jelly-like fuel and, at the same time, having the wick at which flame is produced removed from direct association with said fuel although receiving inflammable material therefrom. In other words, the provision of the wick 24 and the fuel chamber receiving the same is of importance because the inflammable material as existing in said last named chamber is believed not to have the jelly-like characteristics of that in the capsule C1. Accordingly, any disadvantage attendant to the use of a single wick in association with a body of jelly-like fuel are overcome.

Although I have described my invention in connection with lighter mechanism and operating parts of a particular type, it shall be understood that my invention is not to be so limited. My invention is of broad and general application and may be practiced with any desired arrangement for producing sparks whether by automatic mechanism, by "thumb-wheel" lighters, or otherwise.

While the invention has been described with respect to certain particular preferred examples which give satisfactory results, it will be understood by those skilled in the art after understanding the invention, that various changes and modifications may be made without departing from the spirit and scope of the invention and it is intended therefore in the appended claims to cover all such changes and modifications.

What is claimed as new and desired to be secured by Letters Patent is:

1. In pyrophoric lighting mechanism, the combination with a plate, of a fuel chamber, a wick, spark-producing mechanism, and operating means for said mechanism all carried by said plate, and a skirt section depending from said plate, said skirt section enclosing said fuel chamber and parts of said mechanism and operating means, said plate being adapted for detachable association with the top of a casing.

2. In pyrophoric lighting mechanism, the combination with a plate, of a fuel chamber, a wick, spark-producing mechanism, and operating means for said mechanism all carried by said plate, and a skirt section depending from said plate, said skirt section enclosing said fuel chamber and parts of said mechanism and operating means, said plate being adapted for detachable association with the top of a casing, said plate comprising an outwardly extending flanged section adapted to rest upon said casing.

3. In pyrophoric lighting mechanism, the combination with a plate, of a fuel chamber, a wick, spark-producing mechanism, and operating means for said mechanism all carried by said plate, a skirt section depending from said plate, a casing, a fuel casing therein, said plate being detachably associated with the top of said cas-

ing, said mechanism and operating means comprising tube-like members depending below said plate, said fuel chamber and said tube-like members terminating only slightly above the top wall of said fuel casing.

4. Pyrophoric lighting mechanism comprising a casing, a plate adapted for detachable association with said casing and forming the top wall thereof, spark-producing means carried by said plate, a fuel chamber depending into said casing from said plate, a wick in said fuel chamber and extending through said plate to the vicinity of said spark producing means, a fuel-containing casing detachably retained in said first named casing, a spring on which said fuel-containing casing is seated, means forming a passage between said fuel-containing casing and said chamber, said spring biasing said fuel-containing casing upwardly whereby said passage is maintained closed, and a wick in said fuel-containing casing and extending toward said passage.

5. Pyrophoric lighting mechanism comprising a casing, a plate forming the top wall of said casing, spark-producing means carried by said plate, operating means for said spark-producing means, a fuel chamber depending into said casing from said plate, a wick in said fuel chamber and extending through said plate to the vicinity of said spark-producing means, and a fuel-containing casing in said first named casing and having a passage communicating with said fuel chamber, said fuel chamber being disposed adjacent one side of said casing and a member of said operating means being disposed adjacent the other side of said casing, the pyrophoric metal tube of said spark-producing means together with the biasing spring for said pyrophoric metal being disposed between said fuel chamber and said member.

6. Pyrophoric lighting mechanism comprising a casing, a plate adapted for detachable association with said casing and forming the top wall thereof, spark-producing means carried by said plate, operating means for said spark-producing means, a fuel chamber depending into said casing from said plate, a wick in said fuel chamber and extending through said plate to the vicinity of said spark-producing means, a fuel-containing casing readily slidable within said first named casing, a spring on which said fuel-containing casing is seated, means forming a passage between said fuel-containing casing and said chamber, said spring biasing said fuel-containing casing upwardly whereby said passage is maintained closed, and a wick in said fuel-containing casing and extending toward said passage, said fuel chamber being disposed adjacent one side of said casing and a member of said operating means being disposed adjacent the other side of said casing, the pyrophoric metal tube of said spark-producing means together with the biasing spring for said pyrophoric metal being disposed between said fuel chamber and said member.

LOUIS V. ARONSON.