

April 19, 1932.

C. DOERR, SR

1,854,985

ELECTRIC LIGHTER FOR CIGARS, CIGARETTES, AND THE LIKE

Filed Jan. 10, 1930

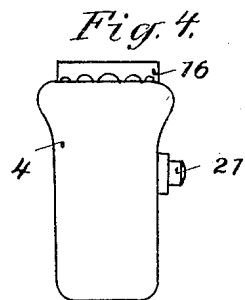
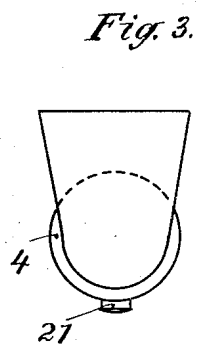
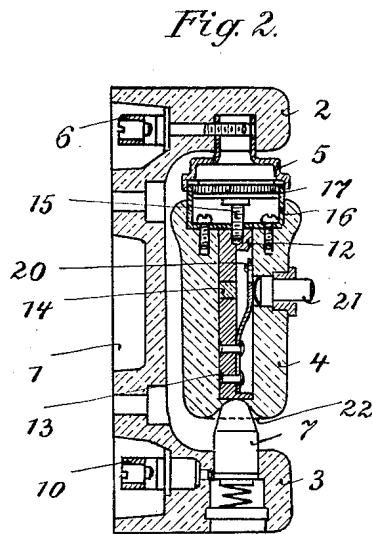
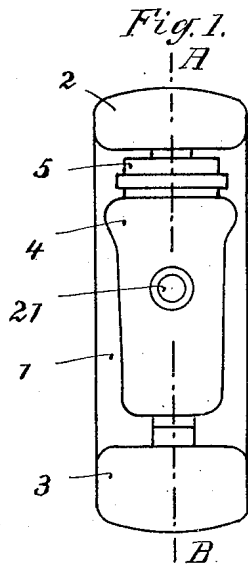

Inventor:

Carl Doerr sen.

UNITED STATES PATENT OFFICE

CARL DOERR, SR., OF NIEDER-RAMSTADT, NEAR DARMSTADT, GERMANY

ELECTRIC LIGHTER FOR CIGARS, CIGARETTES AND THE LIKE

Application filed January 10, 1930, Serial No. 419,966, and in Germany January 10, 1929.

This invention relates to electric lighters for cigars, cigarettes and the like, of the type comprising a body portion of insulating material adapted to be secured to a fixed support, as the instrument board of a motor driven vehicle, a lighter unit adapted to be removably supported on said body portion, a heating element of electrical resistant material, electrical contacts and conductors connected in circuit with said heating element, and a switch which controls said circuit.

A principal object of the invention is to provide an electric lighter of the type specified, of novel construction and arrangement whereby the switch controlling the electric circuit may be manipulated and the lighter unit removed from the body portion of the lighter conveniently and expeditiously, using one hand only.

A further object of the invention is to provide a lighter of the type specified, in which the contacts for connecting the heating element electrically will form a guard constructed and arranged to enclose said heating element thereby preventing accidental contact therewith when the lighter element is supported on the base, which might result in the clothing or person of an individual being burned by contact therewith when the heating element is incandescent, said guard also being constructed to render said heating element visible, whereby a person desiring to use it may know when it is incandescent.

To effect the objects thereof, an electric lighter embodying my invention and improvements, comprises the various features, combinations of features and details of construction hereinafter described and claimed.

In the accompanying drawings, in which the invention is fully illustrated,

Fig. 1 is a front view of an electric lighter embodying my invention and improvements.

Fig. 2 is a sectional view thereof on the line A—B of Fig. 1.

Fig. 3 is an end view from a position above Fig. 1; and

Fig. 4 is a detached side view of the lighter unit.

Describing the invention with reference to the drawings, my improved lighter comprises

a base portion 1 made of suitable insulating material, as bakelite, adapted to be secured to a suitable support, as the instrument board of a motor vehicle, not shown, as by screws inserted through holes provided for the purpose.

Formed at the ends of that side of said body portion which is exposed when said lighter is installed for use, are projections 2 and 3 between which a lighter unit 4 comprising a handle portion also made of insulating material, preferably bakelite, is adapted to be removably supported.

As shown, opposite ends of the lighter unit 4 are adapted to be removably secured to the projections 2 and 3, respectively, in the following manner: Secured to the projection 2 is a cap 5, which, as shown, is made of sheet metal which is a good conductor of electricity and which comprises a reduced shank portion which closely fits a hole formed in said projection 2 and is secured therein by a screw which forms part of the binding post 6, as shown. Formed around the open side of the cap 5 is a flanged seat which is adapted to receive and interlock with an annular flange forming part of a member 16 secured in a recess formed in the end of the handle portion of the lighter unit 4 designed to be supported on the projection 2, by screws, as shown, or other suitable means. The member 16 is made of sheet metal which is a good conductor of electricity, secured in the open side of which is a heating element 17 made of electrical resistant material, connected electrically as presently described. In the preferable construction shown, also, the cap 5 and member 16 are shaped so that when the lighter unit 4 is supported on the base 1, said cap 5 and member 16 will form a guard which will enclose the heating element 17, thereby preventing unintentional contact therewith. As shown, also, see particularly Fig. 4, the member 16 is provided with holes or perforations through which said heating element is visible, thus indicating to a user when it is incandescent.

As shown, also, the means for removably supporting the lighter unit 4 on the projection 3 of the base portion of the lighter, con-

sists of a spring-pressed bolt 7 made of metal which is a good conductor of electricity, said bolt being fitted to a bearing formed in said projection 3, so as to be movable endwise therein, and which is adapted to engage a recess 22 formed in the end of the handle portion of the lighter unit 4 designed to be supported on said projection 3.

As shown, the recess 22 and the end of the bolt 7 which engages said recess, are tapered, the extreme end of the bolt being rounded. Said bolt is maintained yieldingly in locking position by the spring applied thereto, as shown.

As shown, the electrical contacts and connections of the lighter comprise the binding post 6, the screw forming part thereof by which the cap 5 is secured to the projection 2 of the body portion of the lighter, the cap 5, the flanged member 16, which is in electrical contact with said cap when the lighter unit is supported on the body portion of the lighter, the binding post 10 a part of which contacts with the bolt 7, which, as stated, is made of metal which is a good conductor of electricity, electric conductors 12 and 13 mounted in fixed position in an axial hole formed through the handle portion of the lighter unit 4, adjacent ends of said conductors being separated by insulating material, as shown at 14.

The heating element 17 is electrically connected at a point or points on its periphery with the flange of the member 16 and is electrically connected at its center by a screw 15, which engages said heating element centrally and the lower end of which has threaded engagement with a hole formed in the proximate end of the contact 12. As shown, also, the underside of the element 17 rests on and is supported by a nut threaded to the screw 15, as shown. The disk portion of the member 16 necessarily will be insulated from the screw 15 and also from the upper end of the conductor 12. While means for this purpose are not shown or described in detail, such means readily can be supplied by skilled electricians without the exercise of invention.

The conductors 12 and 13 are adapted to be electrically connected by a suitable switch consisting, as shown, of a spring 20 made of metal which is a good conductor of electricity, one end of which is secured to one of said conductors—as shown, the conductor 13—the free end of which is adapted to be depressed into contact with the conductor 12 by a switch button 21 made of non-conducting material, thereby closing the electric circuit between the binding posts 6 and 10 through the heating element 17, which thereupon will become incandescent and ready to be removed from the base 1 for use.

Particular advantages inherent in my improved lighter are that the switch button may be depressed and the lighter unit 4 moved

down against the force of the spring applied to the locking bolt 7 simultaneously and with the use of one hand only; and that, as mounted for use, the heating element 17 is enclosed, thereby preventing unintentional contact therewith, while at the same time it is visible so that a person using it may know when it is in condition for use.

I claim:

1. An electric lighter comprising a base portion of insulating material having spaced projections, a lighter unit comprising a handle portion of insulating material having a heating element of electrical resistant material in one end, means for removably mounting said lighter unit between the projections on the base portion of the lighter comprising relatively fixed interlocking parts on one of said projections and on the end of the body portion of the lighter unit to which the heating element is secured, a bolt movable endwise in a bearing in the other projection on the base adapted to interlock with a recess formed in the end of the body portion of said lighter unit other than that in which the heating element is secured, a spring applied to said bolt for maintaining it yieldingly in locking position, contacts and conductors for connecting the heating element electrically, and a switch on said lighter unit which controls said circuit permitting said switch to be manipulated and said lighter unit to be removed from the base by the use of one hand only.

2. An electric lighter comprising a base portion of insulating material, a lighter unit comprising a handle portion of insulating material having a heating element of electrical resistant material in one end, means for removably mounting said lighter unit on the base portion of the lighter comprising relatively fixed interlocking parts on said base and on the end of said lighter unit to which the heating element is secured, said interlocking parts being made of sheet material which is a good conductor of electricity forming an electrode with which the heating element is in electric circuit and which are shaped and arranged to enclose said heating element when the lighter unit is operatively engaged with the base portion of the lighter.

3. An electric lighter as specified in claim 2, in which an interlocking part for mounting the end of the lighter to which the heating element is secured is provided with perforations through which the heating element is visible when enclosed by said interlocking parts.

4. An electric lighter comprising a base portion of insulating material, a lighter unit comprising a handle portion of insulating material having a heating element of electric resistant material in one end, and means for removably mounting said lighter unit on the base portion of the lighter comprising a

spring-pressed bolt movable endwise in a bearing in the base of the lighter adapted to detachably interlock with a recess in the end of the handle portion of the lighter remote from the heating element.

5 5. An electric lighter as specified in claim 4, in which the spring-pressed bolt forms part of the electric circuit of the lighter.

10 In testimony whereof I hereunto affix my name.

CARL DOERR, Sen.

15

20

25

30

35

40

45

50

55

60

65