

PATENT SPECIFICATION

Convention Date (United States): April 9, 1934.

435,667

Application Date (in United Kingdom): Dec. 22, 1934. No. 36870/34.

Complete Specification Accepted: Sept. 25, 1935.



COMPLETE SPECIFICATION

Improvements in or relating to Pyrophoric Lighters

We, ART METAL WORKS, INC., a corporation organised under the laws of the State of New Jersey, United States of America, of 46—50, Center Street, Newark, New Jersey, United States of America, (Assignees of LOUIS VINCENT ARONSON), do hereby declare the nature of this invention and in what manner the same is to be performed, to be particularly described and ascertained in and by the following statement:—

This invention relates to lighters utilizable for any desired purpose such, for example, as for the ignition of cigarettes, pipes, cigars or the like.

The invention has particular reference to a lighting device of the type embodying pyrophoric spark-producing mechanism adapted to be easily actuated for the purpose of igniting a charge of fuel carried by a suitable torch, which torch after being ignited may readily be moved about for lighting purposes.

The invention has further reference to a pyrophoric lighter comprising an actuating member which is depressed by engagement of a torch therewith to thereby supply the power for rotating a sparking wheel, said actuating member being held in depressed position by pressure of the torch and the actuating member holding the torch in line with the path of the sparks as produced by rotation of the sparking wheel.

Various other objects, advantages and features of the invention will become apparent from the following detailed description.

For an understanding of the invention and for an illustration of one of the many forms thereof, reference is to be had to the accompanying drawings, in which:

Figure 1 is a perspective view showing a lighter constructed and operated in accordance with the invention;

Figure 2 is a vertical sectional view, partly in elevation, of the lighter shown in Figure 1;

Figure 3 is a transverse, vertical sectional view, partly in elevation, and is taken substantially on the line 3—3 of Figure 2 looking in the direction of the arrows;

Figure 4 is a transverse, vertical sectional view of the spark-producing mechanism;

Figure 5 is a horizontal sectional view, partly in inverted plan, and is taken on the line 5—5 of Figure 2 looking in the direction of the arrows;

Figure 6 is a perspective view of a laminated structure adapted to be disposed interiorly of the fuel casing;

Figure 7 is a vertical sectional view, partly in elevation, of the lighter shown in Figure 1; and

Figures 8, 9 and 10 are detailed perspective views showing various parts of the novel mechanism.

Referring to the drawing, C represents a main casing which may be of oval or other suitable configuration, such casing being formed from sheet metal or other suitable material. In accordance with a preferred form of the invention, although not necessarily, the main casing C is open at the bottom so as to telescopically and detachably receive a fuel casing F which, likewise, may be formed from sheet metal, or equivalent material. As shown, the fuel casing F may have a base 1 suitably secured thereto, said base 1 serving as a support for the lighter as will be obvious from a consideration of Figure 2.

Secured in any suitable manner to the top of the main casing C is a cover plate 2 which, in accordance with a preferred form of the invention, forms a support for various parts of the hereinafter described operating mechanism.

Adjacent the center thereof, the aforesaid cover plate 2 is provided with a circular opening which receives the upper end of a hollow, cylindrical member 3 vertically secured to said cover plate 2 in any suitable manner. To this end, the member 3 may be provided with a flange 3a which is clamped against the lower cover plate surface by a nut 4 threaded to the extreme upper end of said member 3.

Freely slidable, interiorly of the cylindrical member 3, is a hollow, piston-like member or plunger 5 which may have a cap member 6 threaded into the upper end thereof. This cap member 6 may

define a recess 6a in the upper surface thereof and the lower threaded shank section of said cap member 6 may be formed with a depending pin 6b utilizable for centering a helical spring 7 disposed in the upper end of said member 5.

As shown on the drawing, the cylindrical member 3 is provided with a pair of diametrically aligned, vertically extending slots 3b. The member 5 is also provided with a pair of diametrically aligned, vertically extending slots 5b. All of these slots are disposed in aligned relation with respect to each other so as to freely receive a lever 8 extending transversely with respect thereto, one end of said lever 8 being pivoted to a lug 9 depending from the cover plate 2. As illustrated, the lower end of the helical spring 7 engages the lever 8 and the lower surface of said lever 8 engages a knob section 5c of the member 5.

The member 5 further comprises a depending stem section 5d around which is disposed a helical spring 10, the lower end of which rests upon the bottom wall of the cylindrical member 3 and the upper end of which engages the flanged surface 5e of the member 5. The stem section 5d of the member 5 is freely slidable in an opening formed in said bottom wall of the cylindrical member 3. Below this bottom wall, the stem section 5d has a member 11 suitably secured thereto, as by a nut 12, said member 11 extending upwardly and terminating in a lateral section 11a utilizable as hereinafter described.

Secured to and upstanding from the cover plate 2 is a plate-like supporting member 13 on which a pin or axle 14 is horizontally anchored. This pin 14 has a sleeve 15 rotatably mounted thereon, said sleeve 15 having a pinion 16 either formed integrally therewith or anchored thereto so that the sleeve and pinion are rotatable together as a unit. The aforesaid lever 8 comprises an upwardly projecting section 8a which extends through a slot 2a formed in the cover plate 2. As shown on the drawing, this projecting section 8a of the lever 8 is formed with a plurality of rack teeth 8b which mesh with the pinion 16.

A pair of wheels 17 and 18 connected together for movement as a unit are loosely mounted on the aforesaid sleeve 15. As shown, the wheel 17 is a sparking wheel and it is formed with a serrated or roughened peripheral surface, such surface coacting with a pyrophoric element 19 disposed in the end of an elongated tube 20 suitably anchored in the cover plate 2. A suitable coil spring, not shown, which is disposed in the tube 20

seats against the upper end of a headed screw 21 and serves to bias the pyrophoric element 19 into engagement with the serrated surface of the wheel 17. The wheel 18 is formed with ratchet teeth on its periphery and coactable therewith is a suitable pawl 22 which, preferably, is of spring steel and so mounted that it tends to swing in a clockwise direction, Figure 2, about its support 22a, the latter being a projecting section of a disk 23 mounted on that end of the sleeve 15 removed from the pinion 16, said disk 23 being suitably fixed to said sleeve 15 so as to be rotatable therewith as a unit and a nut 24, if deemed necessary, being threaded to the otherwise free end of the pin 14.

From a consideration of the drawing, it will be observed that the spark-producing mechanism above described is disposed adjacent the cap member 6. Such mechanism is so positioned and arranged that the sparks produced by clockwise rotative movement of the wheel 17, Figure 2, pass along a diverging path which extends above the cap member 6. Preferably, the spark-producing mechanism is enclosed by a cap structure 25 which is secured to the cover plate 2 in any suitable manner, not shown. This cap structure is provided with a passage 25a through which sparks are adapted to pass along the path above noted.

Suitably secured to the cover plate 2 and depending therefrom is a plate-like supporting member 26 to the lower flanged surface of which the aforesaid elongated tube 20 may be suitably secured, if desired. Pivoted at 27 to the member 26 and suitably spaced therefrom by a spacing washer is a lever 28 which extends in a generally vertical direction and comprises a notched section 28a coactable with a member 29 projecting from the aforesaid lever 8. The lever 28 further comprises a section 28b which extends in generally a horizontal direction and is so positioned that the end thereof is in the path of the lateral section 11a of the aforesaid member 11. The lever 28 is suitably biased in a clockwise direction, Figure 2, and, to this end, there may be utilized a spring 30 which is coiled around the aforesaid spacing sleeve, one end 30a of said spring engaging the lever 28 and the other spring end 30b engaging the member 26.

The above noted fuel casing F, in correspondence with the configuration of the main casing C, may be and preferably is of oval configuration and, preferably, said fuel casing F is detachably received in the lower end of the main casing C. As shown, said fuel casing F, when the

70

75

80

85

90

95

100

105

110

115

120

125

130

elongated tube 20 is of sufficient length, may have a cup-shaped member 31 seated therein, this member 31 receiving the lower end of the tube 20.

5 Frictionally and detachably secured to the upper surface of the fuel casing F is a cap 32 which comprises a depending sleeve-like section 32a adapted to be introduced interiorly of the upper end of a vertical passage defined by a structure 33 formed from a strip of suitable laminated material, such as felt, which is spirally wound in the manner indicated in Figure 6 and retained in such configuration by adhesive secured to the adjacent surfaces of the felt strip. Preferably, a member 15 34 of open mesh material, such as may be fabricated from copper wire, is disposed around the structure 33 to more firmly retain it in the configuration indicated. Further, as shown in Figure 2, the lower end of the passage defined by said structure 33 may be closed by a wad 20 35 of suitable absorbent material or the like.

As illustrated in Figure 2, the fuel casing F contains a mass of suitable absorbent material 36 such, for example, as cotton. Assuming that this absorbent material 36 together with the structure 33 has been disposed within the fuel casing F as shown, the cap 32 may be secured to the top wall of said fuel casing F with the sleeve section 32a thereof depending into the upper part of the passage defined by the structure 33. In this manner, said structure may be held interiorly of the fuel casing F in the position shown in Figure 2.

40 The aforesaid cover plate 2 is formed with an opening for the reception of a tubular member 37 which depends from and is anchored to said cover plate 2, the interior passage defined by this tubular member being open at both ends and disposed in alignment with the passage defined by the aforesaid sleeve-like section 32a of the cap member 32.

As shown in Figure 2, the aforesaid tubular member 37 is adapted to receive, in readily detachable manner, an elongated member 38 formed with a handle section 38a, the lower flanged surface of which rests upon the upper end of said tubular member 37. The lower part of the member 38 is shown as received by the continuous passage formed in the cap member 32 and the structure 33.

The member 38 is formed of suitable material such as metal and, as illustrated in Figure 7, it is of tubular construction and has a stem 39 of metal or equivalent material, this stem carrying a detachable fabric sleeve 40 formed, for example, from cotton or asbestos strands woven or

knitted to form the fabric. The lower end of the stem 39 terminates in a head 41 having a reduced section 41a adapted to be inserted into and frictionally engage the lower interior surface of the member 38. As clearly shown on the drawing, the lower end of the member 38 is cut away to form one or more passages 38b whereby the underlying section or sections of the fabric sleeve 40 are exposed.

With the form of the invention herein illustrated, the fuel casing F may be removed from the main casing C when it becomes necessary to refuel said casing F, the fuel which is thus utilized being of any suitable kind such, for example, as heretofore utilized for supplying conventional pyrophoric lighters. With the present invention, it is desirable that a high test gasoline be utilized for fueling purposes and, accordingly, with the fuel casing F removed from the main casing C, a suitable quantity of such gasoline may be introduced into said fuel casing by passing the same through the opening in the cap 32 thereof. This fuel is taken up largely by the absorbent material 36 and to some extent by the felt structure 33.

With the various parts of the mechanism in normal position as shown in Figure 2, fuel fumes or liquid fuel as such passes from the absorbent material 36, through the open mesh section 34, and through the felt structure 33, the fuel being then absorbed by the fabric sleeve 40 which, as stated, is disposed within the tubular member 38. Due to the fact that the fabric sleeve 40 extends upwardly within the tubular member 38, it results that the upper part of said fabric sleeve takes up a quantity of fuel and, therefore, in a sense, acts as a fuel reservoir of limited capacity.

With the parts in normal position as shown in Figure 2, it will be obvious that the lower end of the tubular member 38 serves as a closure for the fuel casing F. This is necessarily true since a close fit exists between said tubular member and the sleeve section 32a of the cap member 32. The vertical passage in the felt structure 33 is somewhat smaller in diameter than that of the tubular member 38 and, therefore, the latter is resiliently engaged and gripped by said felt structure 33 to thereby enhance the sealing action to some extent.

When the herein described mechanism is to be operated, the handle section 38a is grasped by the fingers of one hand and lifted upwardly to entirely remove the member 38 from the tubular member 37. The member 38 is then disposed in the position shown in Figure 1 with the head 41 at the lower end thereof disposed with-

70

75

80

85

90

95

100

105

110

115

120

125

130

in the recess 6a of the cap member 6. While thus held in substantially vertical position, downward pressure is applied to the member 38 and, as a result, the member 5 is moved downwardly within the hollow cylinder 3 to thereby compress the springs 7 and 10. During this initial downward movement of the member 5, the lever 8 remains stationary by reason of the fact that the lateral pin 29 thereof is in engagement with the notched section 28a of the lever 28.

As hereinbefore stated, the stem section 5d of the member 5 and the member 11 are connected to the member 5 for movement together as a unit. Accordingly, during downward movement of the member 5, the lateral section 11a of the member 11 moves downwardly and eventually comes into engagement with the end of the lever section 28b. The various parts are shown in Figure 7 in the respective positions occupied thereby just after the lateral section 11a of the member 11 has engaged the end of said lever section 28b. During slight continued downward movement of the member 11, the lever 28 is rocked further in a counterclockwise direction, Figure 7, to entirely disengage the notched lever end 28a from the pin 29. When disengagement is thus effected, the lever 8, which heretofore has served as a stop surface for the bottom section of the spring 7, is freed from restraint and, accordingly, said spring 7 expands suddenly to thereby rock said lever 8 in a clockwise direction, Figures 2 and 7, in a snapping manner. In response to such movement of the lever 8, a quick step of rotative movement is imparted to the pinion 16, the sleeve 15 and the disk 23. The pawl 22 is carried by the disk 23 and, accordingly, in response to such rotative movement of the disk 23, said pawl 22 serves to impart a step of rotative movement to the ratchet wheel 18 in a clockwise direction, Figures 2 and 7. The serrated wheel 17 moves with the ratchet wheel 18 as a unit and, therefore, said serrated wheel 17 partakes of a quick step of rotative movement and, because engaged by the pyrophoric element 19, serves to produce a shower of sparks which are directed along a path extending toward and above the cap member 6. Inasmuch as the member 38 is pressed downwardly against the cap member 6 at this time, it results that the pyrophoric sparks ignite the fuel carried by the exposed sections of the fabric sleeve 40. As a result of the foregoing, a flame is produced at the lower end of the member 38 which becomes, in effect, a torch, and, as such, it may be used to perform any desired lighting operation. The torch

may readily and quickly be conveyed to any object to be ignited and, in so doing, it may be passed from hand to hand or to different persons in order to accomplish a plurality of lighting operations.

After the member 38 has served its intended purpose as a torch, it may be reinserted into and passed downwardly through the tubular member 37. By so doing, the flame is necessarily extinguished although, of course, the flame may be extinguished prior to reinsertion of said member 38 into the tubular member 37. As soon as the member 38 has been returned to its normal position as shown in Figure 2, fuel is taken up by the wick member 40 at the exposed wick sections defined by the openings 38b. This fuel, to some extent, is absorbed by the upper section of the wick member 40 removed from the openings 38b. The member 38, therefore, is well adapted for subsequent use as a torch because it contains a quantity of fuel sufficient to maintain a freely burning flame for an extended period of time.

When the member 5 was moved downwardly by the member 38 as described, the springs 7 and 10 were compressed. When the notched lever section 28a became disengaged from the pin 29, sudden expansion of the spring 7 occurred and this was accompanied by further compression of the spring 10, the spring 7, at this time, becoming fully expanded or substantially so.

As soon as the torch member 38 is removed from the member 5, the spring 10 is permitted to expand to return the parts to their normal respective positions as shown in Figure 2. In so doing, the member 5 is moved upwardly to elevate the spring 7 and to swing the lever 8 in a counterclockwise direction, Figure 2, to such extent that the pin 29 thereon is again engaged with the notched end 28a of the lever 28 which is biased in a clockwise direction, Figure 2, by the spring 30. When the lever 8 is thus swung in a counterclockwise direction, the pinion 16, sleeve 15 and disk 23 partake of a step of reverse rotative movement. During such movement, the pawl 22 idles with respect to the ratchet wheel 18 and, therefore, this wheel together with the serrated wheel 17 remains stationary.

As clearly appears from a consideration of Figure 2, the spring 7 should be "heavy" while the spring 10 should be "light". That is, the spring 7, to a suitable degree should be more resistant to compression than the spring 10.

The spring 7, or equivalent, of the 130

herein described mechanism serves as a means for actuating the spark-producing means by a snap action to produce the desired shower of sparks. While storing energy in the spring 7 and, thereafter, operation of said spring for the intended purpose is restrained by the latching means comprising the lever 28, or equivalent. In the preferred form of the invention herein shown, energy is stored in the spring 7, or equivalent, and the latching means is released by operating means which comprises the member 38, or equivalent, carrying the charge of fuel. It is to be understood that the mechanism hereinbefore specifically described is illustrative of but one of the many embodiments of the invention. Thus, for example, in lieu of the described spark-producing mechanism, it shall be understood that other equivalent arrangements for obtaining uni-directional movement of a serrated wheel may be utilized. Furthermore, it is to be understood that fuel may be supplied to the fuel casing F in any convenient manner otherwise than as herein described. It will be understood that the part 32 may assume any one of a variety of forms so that in conjunction with the tubular member 38 it may form an effective seal for the fuel casing F in accordance with the broad purview of the invention.

While the invention has been described with respect to a certain particular preferred example which gives satisfactory results, it will be understood by those skilled in the art after understanding the invention, that various changes and modifications may be made without departing from the spirit and scope of the invention and it is intended therefore in the appended claims to cover all such changes and modifications.

Having now particularly described and ascertained the nature of our said invention and in what manner the same is to be performed, we declare that what we claim is:—

1. A pyrophoric lighter having a sparking wheel mounted on a receptacle and against which a pyrophoric metal piece bears, and a sparking wheel actuating member located substantially in the plane of the sparking wheel, and comprising a spring adapted to urge the actuating member toward a position at one limit of its stroke wherein the actuating member is idle, a manually operable torch engageable with the

actuating member to depress the latter into a position at the opposite limit of its stroke and hold it in such position, said actuating member when in the latter or depressed position holding the torch in position to receive sparks projected from the sparking wheel, and mechanism interposed between the actuating member and the sparking wheel whereby the pressure of the torch against the actuating member is transmitted to the sparking wheel and utilized to turn the wheel and thereby project sparks against the torch while the latter is pressing against the actuating member.

2. A pyrophoric lighter according to claim 1, in which the said mechanism includes a spring in which energy is stored during the initial part of the depression of the actuating member, and a latch positioned to release the spring, and members interposed between the spring and the sparking wheel to rotate the latter when the spring is released by the latch.

3. A pyrophoric lighter comprising a receptacle, a rotatable sparking wheel, a pyrophoric metal piece bearing against said wheel, a reciprocable actuating member, a first spring, mechanism connecting said spring and sparking wheel, a torch engageable with the actuating member to depress the latter upon application of manual pressure thereto and store energy in said spring, a latch restraining operation of the spring, continued depression of the actuating member releasing the latch whereby the spring becomes effective to rotate the sparking wheel, and a second spring adapted to be compressed by the actuating member and which spring is further compressed, upon release of the latch, by the energy stored in the first spring, said second spring restoring the parts to normal position upon removal of the torch from the actuating member.

4. A pyrophoric lighter having its parts constructed, arranged and adapted to operate substantially as hereinbefore described with reference to the accompanying drawings and for the purpose specified.

Dated the 22nd day of December, 1934.
For: ART METAL WORKS, INC.,
Stevens, Langner, Parry & Rollinson,
Chartered Patent Agents,
5—9, Quality Court, Chancery Lane,
London, W.C.2, and at
17, John Street, New York, U.S.A.

[This Drawing is a reproduction of the Original on a reduced scale.]

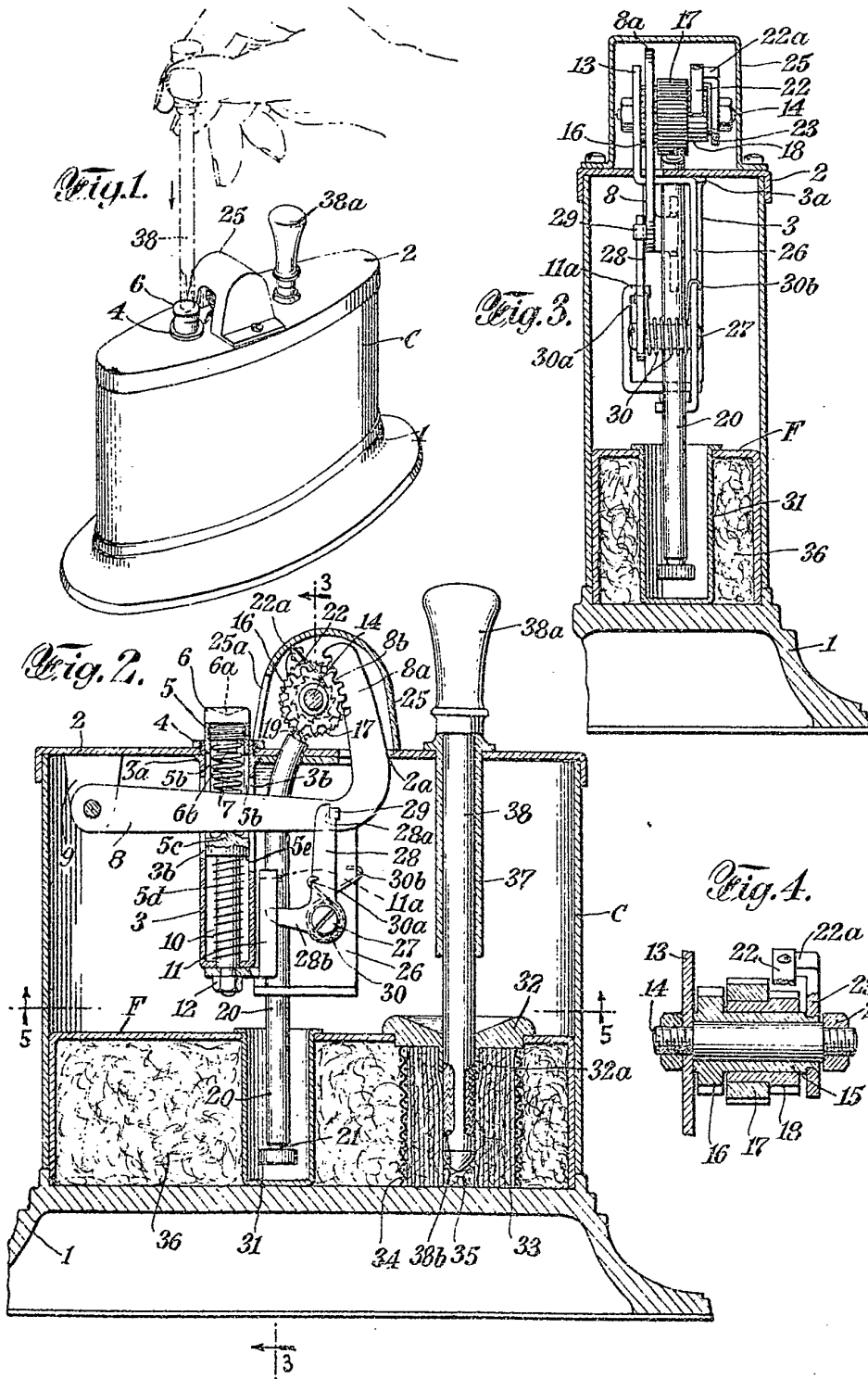

Fig. 5.

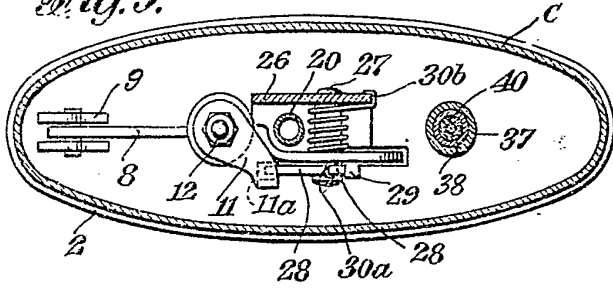

Fig. 8.

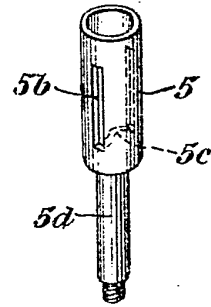

Fig. 6.

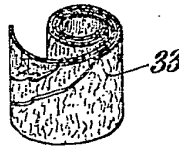

Fig. 9.

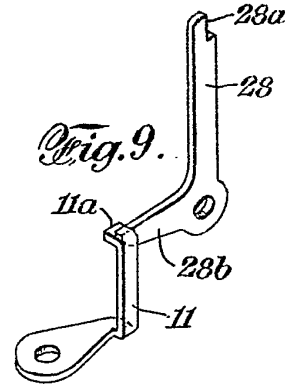

Fig. 7.

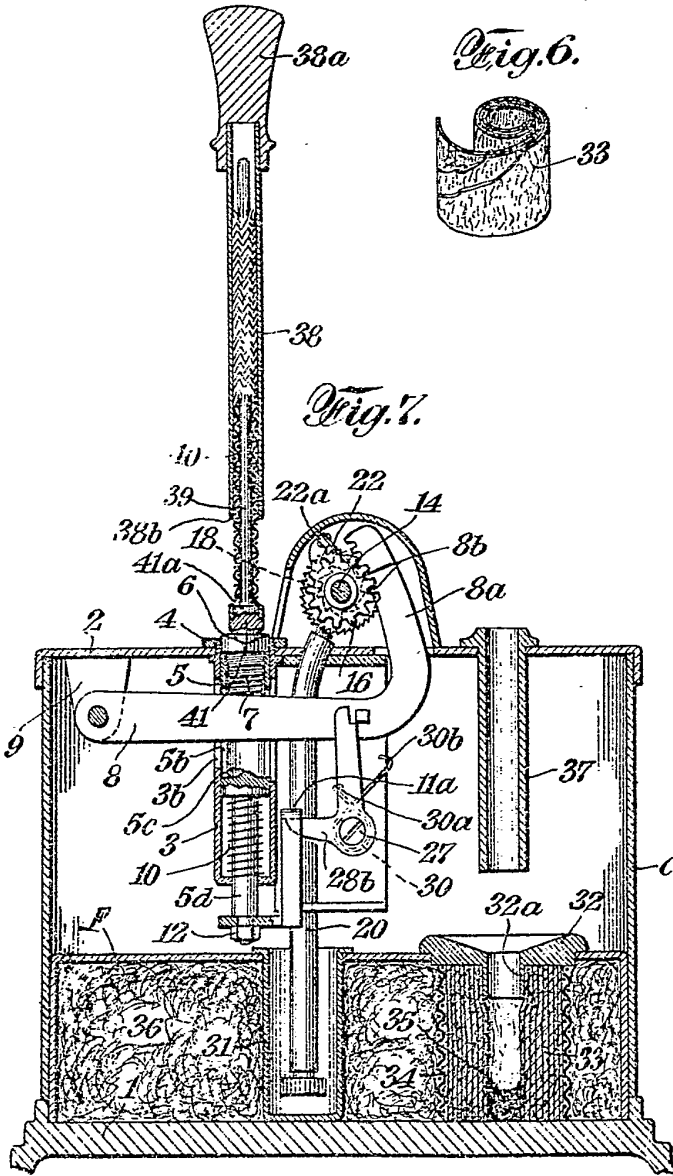
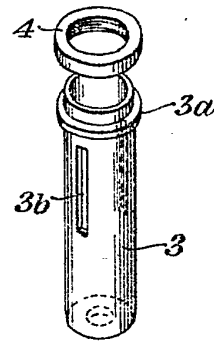

Fig. 10.



1



2a



15

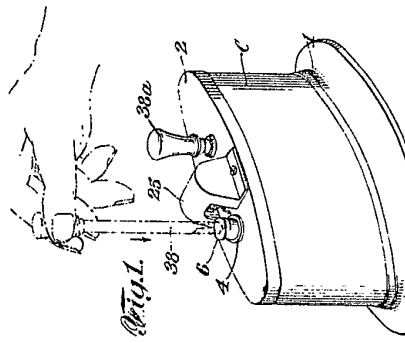

Fig. 1.

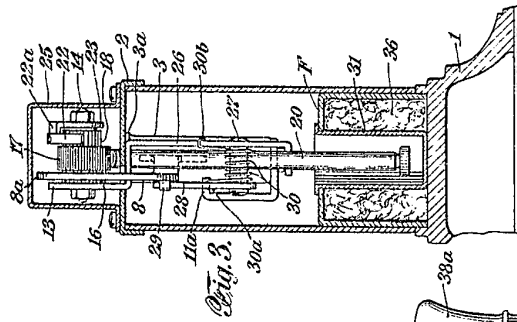

Fig. 2.

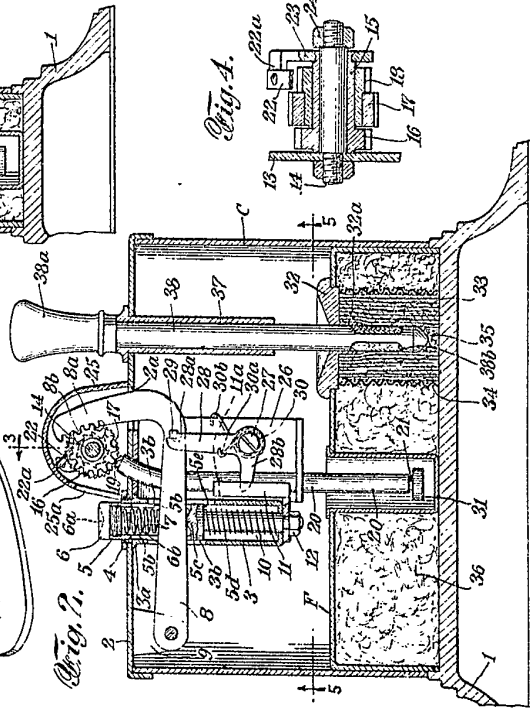

Fig. 3.

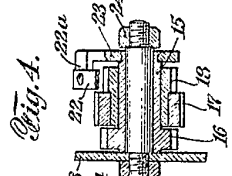

Fig. 4.

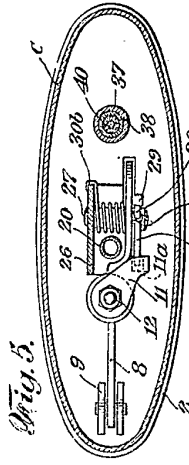

Fig. 5.



Fig. 6.

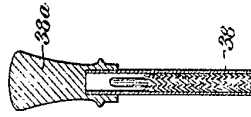

Fig. 7.

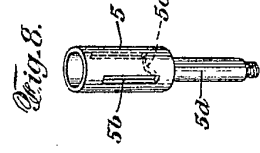

Fig. 8.

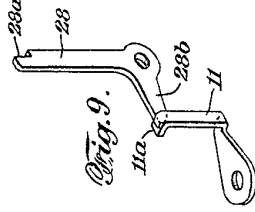

Fig. 9.

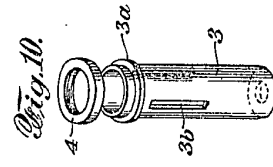

Fig. 10.

[This Drawing is a reproduction of the Original on a reduced scale.]